

Insulated Gate Bipolar Transistor 600V 14A 87W TO-252

MIG60N14T252

MERITEK

FEATURE

- Trench Gate and Field Stop Processes IGBT
- Low Saturation V_{CES} and High Switching Speed
- Positive Temperature Coefficient in Saturation V_{CES}
- Very Tight Parameter Distribution
- High Ruggedness, Temperature Stable Behavior
- Application: Frequency Inverters, Motor Control, Static Relays

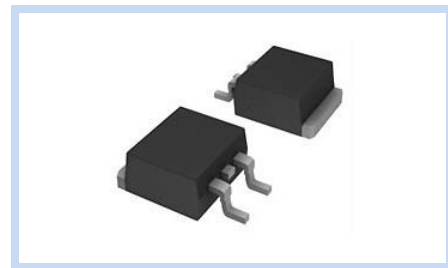

MECHANICAL DATA

- Case: TO-252 Package
- Terminals: Solderable per MIL-STD-750, Method 2026

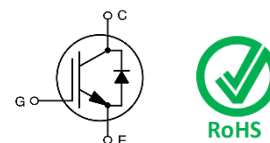

MAXIMUM RATINGS

Parameter	Symbol	Value	Unit
Collector-to-Emitter Breakdown Voltage	V_{CES}	600	V
Gate-to-Emitter Voltage	V_{GE}	± 30	V
Collector Current – Continuous	I_C	$T_C=25^\circ\text{C}$	14
		$T_C=100^\circ\text{C}$	7
Pulse Collector Current	I_{CM}	21	A
Turn Off Safe Operating Area	-	21	A
Diode Forward Current – Continuous	I_F	7	A
Diode Forward Current – Pulsed	I_{FM}	21	A
Power Dissipation	P_D	$T_C=25^\circ\text{C}$	87
		$T_C=100^\circ\text{C}$	43.5
Short Circuit Withstand Time	t_{sc}	5	μs
Thermal Resistance Junction to Case for Diode	$R_{\theta JC}$	2.50	$^\circ\text{C/W}$
Thermal Resistance Junction to Case For IGBT		1.71	
Operating Junction Temperature	T_J	175	$^\circ\text{C}$
Maximum Temperature for Soldering	T_L	260	$^\circ\text{C}$
Storage Temperature Range	T_{STG}	-55 to 175	$^\circ\text{C}$

Note: Allowed number of short circuits: <1000; time between short circuits: >1s

DIMENSIONS

Item	Min (mm)	Max (mm)
A	2.20	2.40
A1	--	0.13
b	0.66	0.86
b2	0.66	0.86
b3	5.10	5.50
c	0.46	0.60
c2	0.46	0.60
D	6.00	6.20
E	6.50	6.70
e	2.186	2.39
H	9.80	10.50
L	1.40	1.80
L1	0.80	2.50
L2	0.60	1.00

Note: 1: Gate(G), 2: Collector(C), 3: Emitter (E).

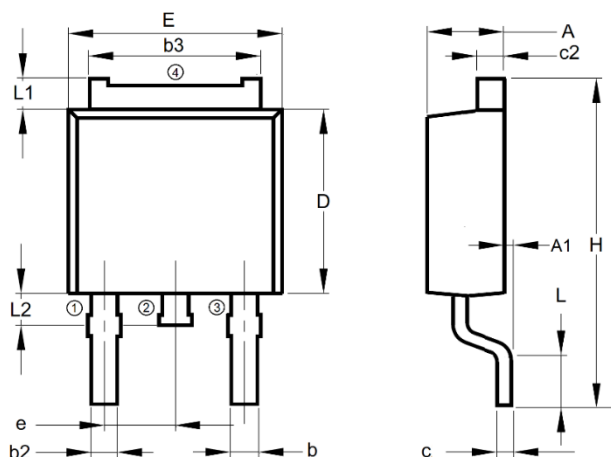

Insulated Gate Bipolar Transistor 600V 14A 87W TO-252

MIG60N14T252

MERITEK

ELECTRICAL CHARACTERISTICS

Static Characteristics	Conditions	Symbol	Min	Typ.	Max	Unit
Collector-Emitter Breakdown Voltage	$V_{GE}=0V, I_C=1mA$	$V_{(BR)CES}$	600	--	--	V
Zero Gate Voltage Collector Current	$V_{CE}=600V, V_{GE}=0V$	I_{CES}	--	--	4	μA
Gate-Body Leakage Current	$V_{GE}=\pm 30V, V_{CS}=0V$	I_{GES}	--	--	± 200	nA
Collector-Emitter Saturation Voltage	$V_{GE}=15V, I_C=5A, T_J=25^\circ C$	$V_{CE(SAT)}$	--	1.7	1.9	V
	$V_{GE}=15V, I_C=5A, T_J=175^\circ C$		--	1.9	--	
Gate Threshold Voltage	$V_{GE}=V_{DS}, I_C=1mA$	$V_{GE(th)}$	4	5	6	V
Diode Forward Voltage	$I_F=7A$	V_F	--	--	2.4	V
Dynamic Characteristics	Conditions	Symbol	Min	Typ.	Max	Unit
Total Gate Charge	$V_{CC}=480V, V_{GE}=15V, I_C=7A$	Q_g	--	28	--	nC
Gate-Emitter Charge		Q_{ge}	--	8	--	
Gate-Collector Charge		Q_{gc}	--	13	--	
Input Capacitance	$V_{CE}=25V, V_{GE}=0V, F=1MHz$	C_{ies}	--	675	--	pF
Output Capacitance		C_{oes}	--	22	--	
Reverse Transfer Capacitance		C_{res}	--	13	--	
Switching Characteristics	Conditions	Symbol	Min	Typ.	Max	Unit
Turn-On Delay Time	$V_{CC}=400V, V_{GE}=0/15V, R_G=5\Omega$ $I_C=7A, T_C=25^\circ C,$ Inductive Load	$T_{d(on)}$	--	20	--	ns
Rise Time		T_r	--	15	--	
Turn-Off Delay Time		$T_{d(off)}$	--	73	--	
Fall Time		T_f	--	18	--	mJ
Turn-On Switching Loss		E_{on}	--	0.21	--	
Turn-Off Switching Loss	E_{off}	--	0.10	--		
Total Switching Loss	E_{TS}	--	0.31	--		
Reverse Recovery Time	$I_F=7A, di_F/dt = 200A/\mu s$	t_{rr}	--	230	--	ns
Reverse Recovery Charge		Q_{rr}	--	0.44	--	μC
Peak Reverse Recovery Current		I_{rr}	--	3.5	--	A

Note: $T_c = 25^\circ C$ unless otherwise noted

Switching Time Waveform

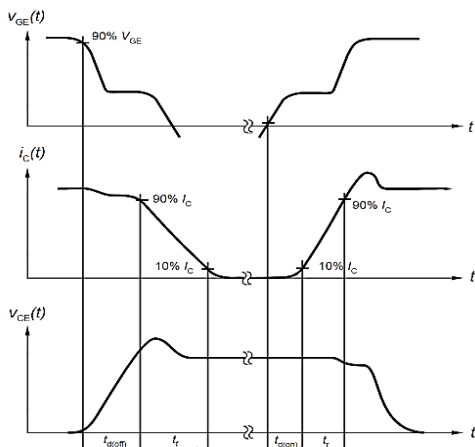

Switching Losses Waveform

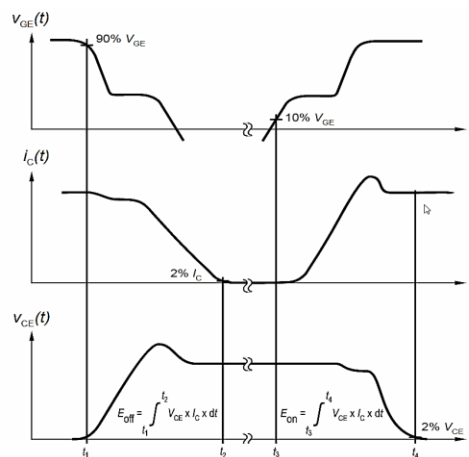

Insulated Gate Bipolar Transistor

600V 14A 87W TO-252

MIG60N14T252

MERITEK

CHARACTERISTIC CURVES

Output Characteristics

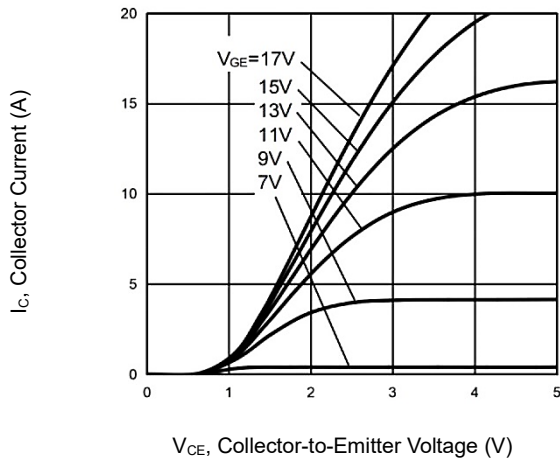

Transfer Characteristics

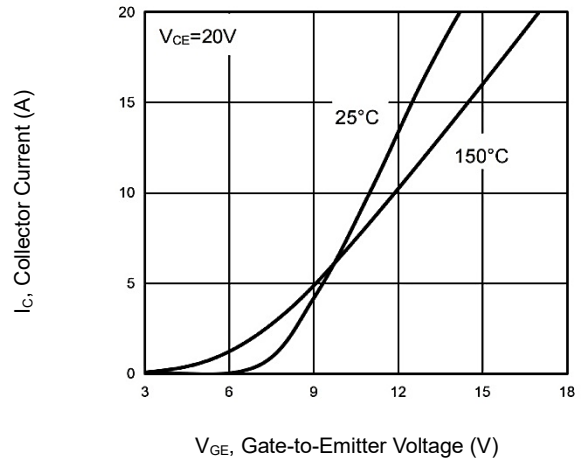

Collector-Emitter Saturation Voltage

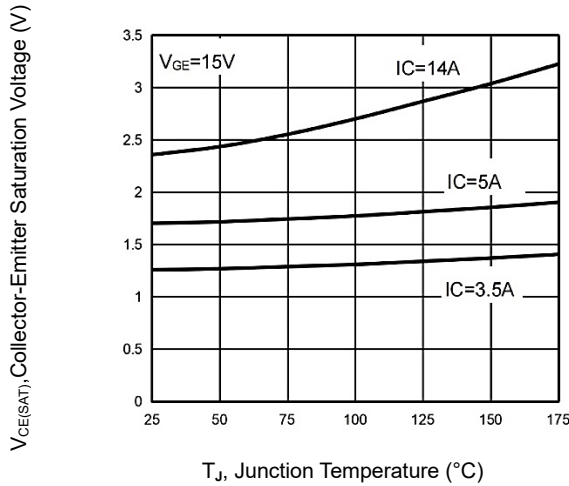

Collector-Emitter Saturation Voltage vs. V_{GE}

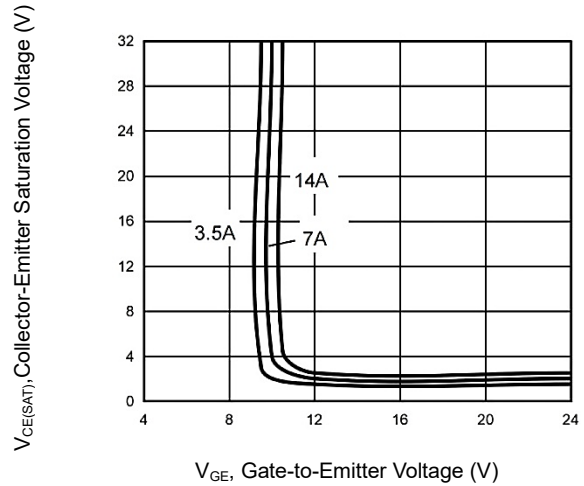

Capacitance Characteristics

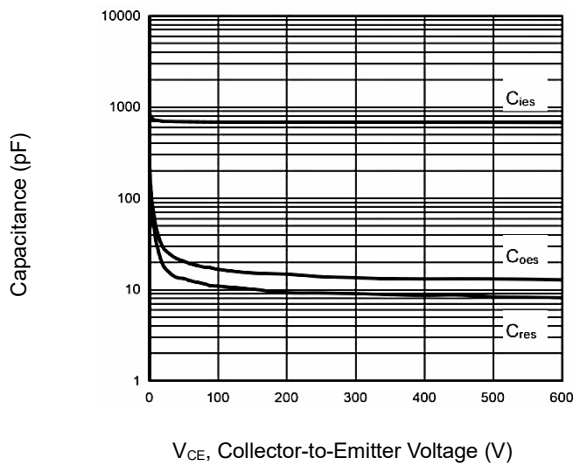

Gate-Charge Characteristics

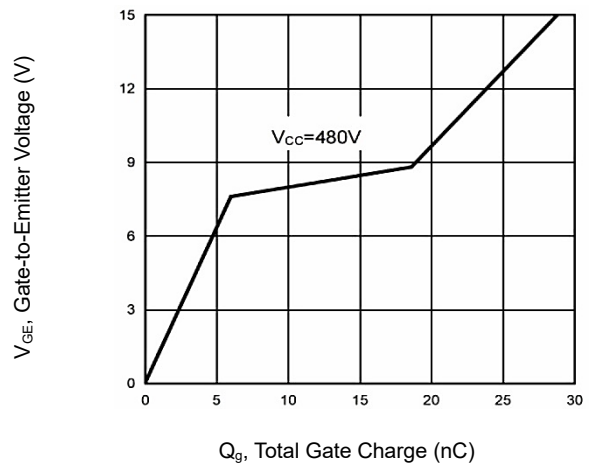

Insulated Gate Bipolar Transistor

600V 14A 87W TO-252

MIG60N14T252

MERITEK

CHARACTERISTIC CURVES

Diode Forward Characteristics

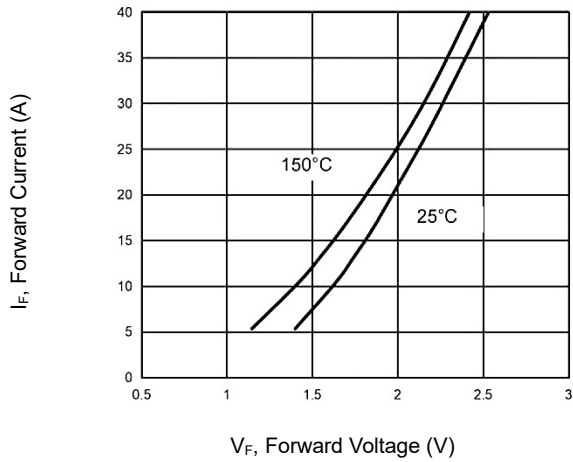

Forward Voltage Variation

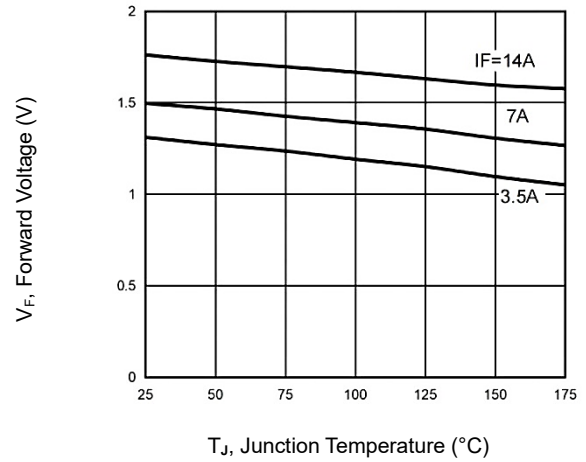

Switching Energy Loss vs Gate Resistances

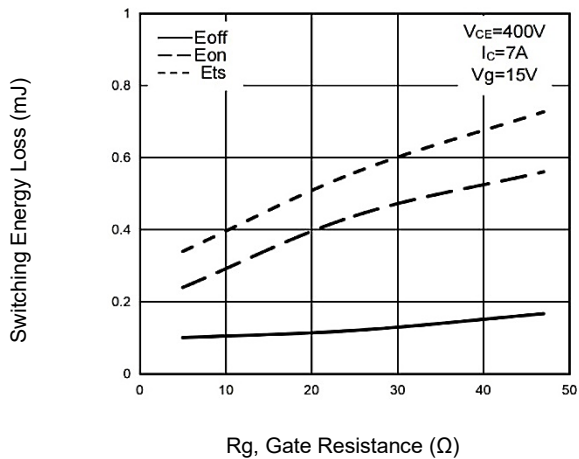

Switching Energy Loss Variation

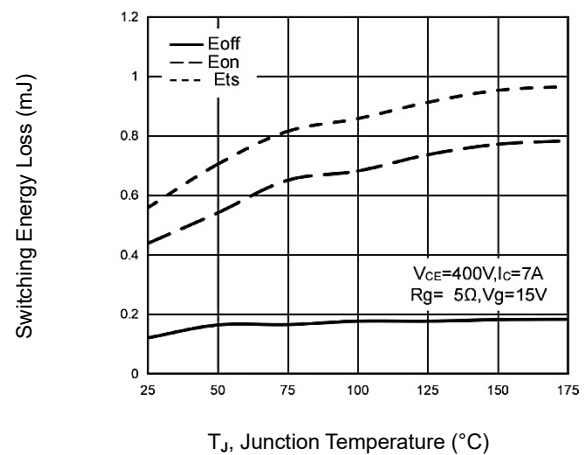

Gate Threshold Voltage Variation

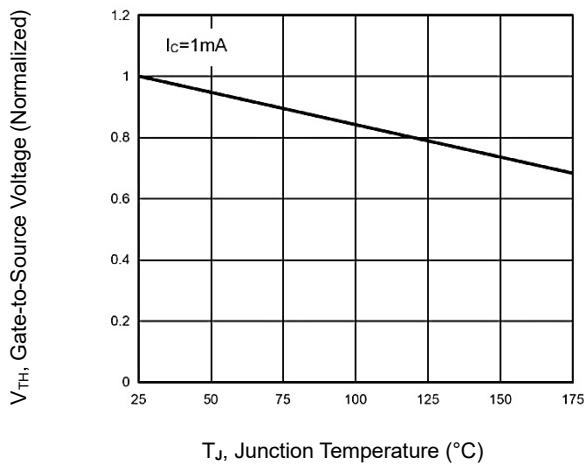

Collector-Emitter Saturation Voltage vs. Ic

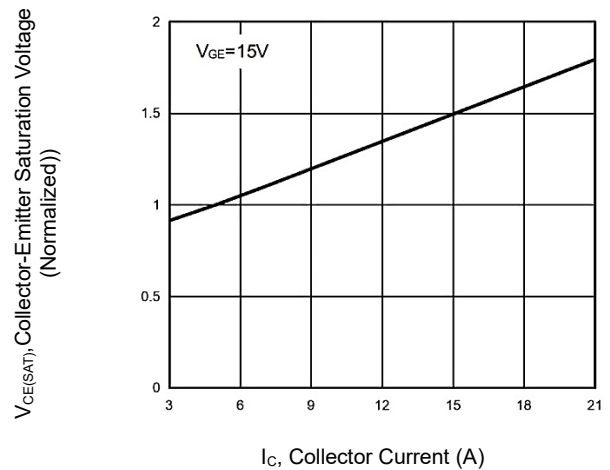

Insulated Gate Bipolar Transistor 600V 14A 87W TO-252

MIG60N14T252

MERITEK

CHARACTERISTIC CURVES

Forward Bias Safe Operating Area

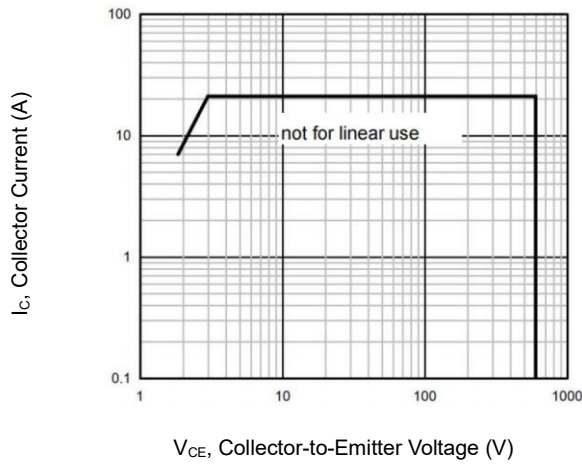

TEST CONDITION

Switching Test Circuit

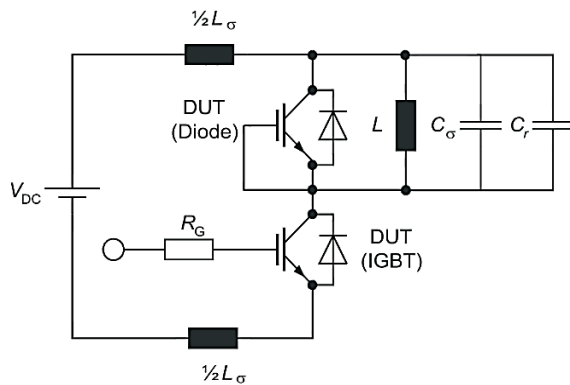

Diode Switching Characteristics

