

EMI Suppression Capacitors Y2 Class 800VDC

MEY-800D Series

MERITEK

FEATURE

- Self-Healing Property
- Dielectric: Metallized Polypropylene Film
- Winding: Non-Inductive Type
- Over Voltage Stress Withstanding
- Flammability Classification 94V-0
- UL/cUL Safety Approved: Certification No: E197475

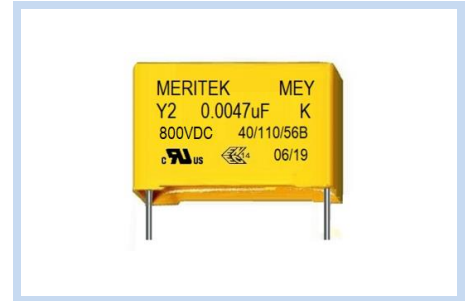

PART NUMBERING SYSTEM

MEY 223 K 800D xxxx
(1) (2) (3) (4) (5)



No	Item	Digit	Description	Reference
(1)	Meritek Series	MEY	EMI Suppression Capacitors	Y2 Class Safety Film Capacitor
(2)	Capacitance	223	223: 22000pF	First two digits: Significant, Third: Multiplier
(3)	Tolerance	K	K: ±10%	±5% (J), ±20% (M)
(4)	Rated Voltage	800D	800D: 800VDC	1K0D:1000VDC, 1K3D: 1350VDC, 1K5D:1500VDC
(5)	Internal Code	xxxx	Pitch or Internal control code	Internal Control or project reference

SPECIFICATIONS

Item	Characteristic	
Operating Temperature Range	-40°C ~ +110°C	
Rated Voltage , Climate Category	800VDC	40/110/56/B
Capacitance, Tolerance	0.001μF ~ 0.1μF,	±5% (J), ±10% (K), ±20% (M)
Dissipation Factor (tan δ)	≤0.1%	at 1KHz ±2%, ≤1.0V _{RMS}
Insulation Resistance	≥ 15,000MΩ (C≤0.33μF) ≥ 5,000MΩ*μF/C (C>0.33μF)	VR=500VAC, Vt=500VDC, 250VAC ≤VR<500VAC, Vt=500VDC, Change Time: 60s ±5s
Withstanding Voltage	Between Terminals	Between Terminals and Case
	2,000VAC for 2sec. or 4,000VDC for 2 sec.	2*Ur+1.5KV _{AC} for 2~5s, Min 2KV _{AC}

DIMENSION

P (mm)	d (mm)	W, H, T (mm)
7.5	0.6	See Table Attached
10.0	0.6	
15.0	0.6	
22.5	0.8	
27.5	0.8	

Note:

1. Standard lead length A: 15mm min.
2. Contact Meritek for other available options for lead forming or assembly

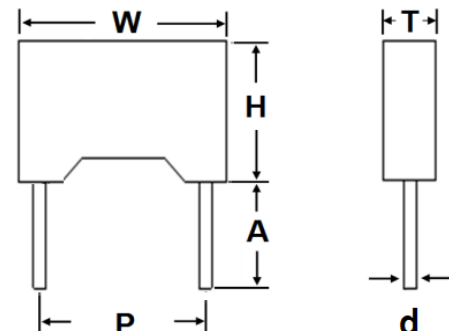

EMI Suppression Capacitors Y2 Class 800VDC

MEY-800D Series

MERITEK

ELECTRICAL SPECIFICATION – 800VDC

Part Number	Cap Code	Cap	Tol	Volt	W	H	T	P	d	Safety
		(uF)	(%)	(V _{DC})	(mm)	(mm)	(mm)	(mm)	(mm)	Compliance
MEY102□800D75	102	0.0010	J,K,M	800	10.5	9.0	4.0	7.5	0.6	UL,cUL,ENEC
MEY152□800D75	152	0.0015	J,K,M	800	10.5	9.0	4.0	7.5	0.6	UL,cUL,ENEC
MEY222□800D75	222	0.0022	J,K,M	800	10.5	11.0	5.0	7.5	0.6	UL,cUL,ENEC
MEY272□800D75	272	0.0027	J,K,M	800	10.5	11.0	5.0	7.5	0.6	UL,cUL,ENEC
MEY332□800D75	332	0.0033	J,K,M	800	10.5	11.0	5.0	7.5	0.6	UL,cUL,ENEC
MEY392□800D75	392	0.0039	J,K,M	800	10.5	11.0	5.0	7.5	0.6	UL,cUL,ENEC
MEY472□800D75	472	0.0047	J,K,M	800	10.5	11.0	5.0	7.5	0.6	UL,cUL,ENEC
MEY562□800D75	562	0.0056	J,K,M	800	10.5	11.0	5.0	7.5	0.6	UL,cUL,ENEC
MEY102□800D10	102	0.0010	J,K,M	800	13.0	11.0	5.0	10.0	0.6	UL,cUL,ENEC
MEY152□800D10	152	0.0015	J,K,M	800	13.0	11.0	5.0	10.0	0.6	UL,cUL,ENEC
MEY222□800D10	222	0.0022	J,K,M	800	13.0	11.0	5.0	10.0	0.6	UL,cUL,ENEC
MEY272□800D10	272	0.0027	J,K,M	800	13.0	11.0	5.0	10.0	0.6	UL,cUL,ENEC
MEY332□800D10	332	0.0033	J,K,M	800	13.0	11.0	5.0	10.0	0.6	UL,cUL,ENEC
MEY392□800D10	392	0.0039	J,K,M	800	13.0	11.0	5.0	10.0	0.6	UL,cUL,ENEC
MEY472□800D10	472	0.0047	J,K,M	800	13.0	11.0	5.0	10.0	0.6	UL,cUL,ENEC
MEY562□800D10	562	0.0056	J,K,M	800	13.0	11.0	5.0	10.0	0.6	UL,cUL,ENEC
MEY682□800D10	682	0.0068	J,K,M	800	13.0	12.0	6.0	10.0	0.6	UL,cUL,ENEC
MEY822□800D10	822	0.0082	J,K,M	800	13.0	12.0	6.0	10.0	0.6	UL,cUL,ENEC
MEY103□800D10	103	0.0100	J,K,M	800	13.0	12.0	6.0	10.0	0.6	UL,cUL,ENEC
MEY153□800D10	153	0.0150	J,K,M	800	13.0	11.0	5.0	10.0	0.6	UL,cUL,ENEC
MEY123□800D10	123	0.0120	J,K,M	800	13.0	12.0	6.0	10.0	0.6	UL,cUL,ENEC
MEY102□800D15	102	0.0010	J,K,M	800	18.0	11.0	5.0	15.0	0.6	UL,cUL,ENEC
MEY152□800D15	152	0.0015	J,K,M	800	18.0	11.0	5.0	15.0	0.6	UL,cUL,ENEC
MEY222□800D15	222	0.0022	J,K,M	800	18.0	11.0	5.0	15.0	0.6	UL,cUL,ENEC
MEY272□800D15	272	0.0027	J,K,M	800	18.0	11.0	5.0	15.0	0.6	UL,cUL,ENEC
MEY332□800D15	332	0.0033	J,K,M	800	18.0	11.0	5.0	15.0	0.6	UL,cUL,ENEC
MEY392□800D15	392	0.0039	J,K,M	800	18.0	11.0	5.0	15.0	0.6	UL,cUL,ENEC
MEY472□800D15	472	0.0047	J,K,M	800	18.0	11.0	5.0	15.0	0.6	UL,cUL,ENEC
MEY562□800D15	562	0.0056	J,K,M	800	18.0	11.0	5.0	15.0	0.6	UL,cUL,ENEC
MEY682□800D15	682	0.0068	J,K,M	800	18.0	11.0	5.0	15.0	0.6	UL,cUL,ENEC
MEY822□800D15	822	0.0082	J,K,M	800	18.0	11.0	5.0	15.0	0.6	UL,cUL,ENEC
MEY103□800D15	103	0.0100	J,K,M	800	18.0	11.0	5.0	15.0	0.6	UL,cUL,ENEC
MEY123□800D15	123	0.0120	J,K,M	800	18.0	11.0	5.0	15.0	0.6	UL,cUL,ENEC
MEY153□800D15	153	0.0150	J,K,M	800	18.0	11.0	5.0	15.0	0.6	UL,cUL,ENEC
MEY183□800D15	183	0.0180	J,K,M	800	18.0	11.0	5.0	15.0	0.6	UL,cUL,ENEC

Note: 1. □: denotes tolerance code; 2. **: Contact Meritek for Part Number

EMI Suppression Capacitors Y2 Class 800VDC

MEY-800D Series

MERITEK

ELECTRICAL SPECIFICATION – 800VDC

Part Number	Cap Code	Cap	Tol	Volt	W	H	T	P	d	Safety
		(μ F)	(%)	(V _{DC})	(mm)	(mm)	(mm)	(mm)	(mm)	Compliance
MEY223□800D15	223	0.022	J,K,M	800	17.0	11.0	5.5	15.0	0.6	UL,cUL,ENEC
MEY253□800D15	253	0.025	M	800	18.0	12.0	6.0	15.0	0.6	UL,cUL,ENEC
MEY273□800D15	273	0.027	J,K,M	800	17.0	11.0	5.5	15.0	0.6	UL,cUL,ENEC
MEY273□800D15	273	0.027	J,K,M	800	18.0	12.0	6.0	15.0	0.6	UL,cUL,ENEC
MEY333□800D15	333	0.033	J,K,M	800	18.0	12.0	6.0	15.0	0.6	UL,cUL,ENEC
MEY473□800D15	473	0.047	J,K,M	800	18.0	13.5	6.0	15.0	0.6	UL,cUL,ENEC
MEY563□800D15	563	0.056	J,K,M	800	17.0	15.5	7.5	15.0	0.6	UL,cUL,ENEC
MEY683□800D15	683	0.068	J,K,M	800	17.0	15.5	7.5	15.0	0.6	UL,cUL,ENEC
MEY823□800D15	823	0.082	J,K,M	800	17.0	16.5	9.5	15.0	0.6	UL,cUL,ENEC
MEY104□800D15	104	0.100	J,K,M	800	17.0	16.5	9.5	15.0	0.6	UL,cUL,ENEC
MEY473□800D22	473	0.047	J,K,M	800	25.0	14.5	6.0	22.5	0.8	UL,cUL,ENEC
MEY104□800D22	104	0.100	J,K,M	800	26.5	16.5	7.0	22.5	0.8	UL,cUL,ENEC
MEY104□800D27	104	0.100	J,K,M	800	31.5	16.5	7.5	27.5	0.8	UL,cUL,ENEC

Note: 1. □: denotes tolerance code; 2. **: Contact Meritek for Part Number

RELIABILTY AND TEST CONDITIONS

Item	Test Condition	Requirement
Capacitance	Measuring Frequency: $\pm 2\%$; Measuring Voltage: $\leq 1V_{rms}$.	Within the tolerance specified, at $+20\pm 5^{\circ}C$
Withstand Voltage-Between Terminals	Apply 2,000VAC for 2 sec. or 4,000VDC for 2 sec.	Within specified limits
Withstand Voltage - Between Terminals & Enclosure	Apply 2 times of rated voltage + 1.5KV _{AC} for 2~5sec. Min. 2KV _{AC}	Within specified limits
Dissipation Factor	Measuring Frequency: $\pm 2\%$; Measuring Voltage: $\leq 1V_{rms}$.	D.F. : $\leq 0.001(0.1\%)$ at 1KHz
Insulation resistance	VR=500VAC, Vt=500VDC, 250VAC \leq VR < 500VAC, Vt=500VDC, Change Time: 60s \pm 5s	$\geq 15,000M\Omega$ (C \leq 0.33 μ F) $\geq 5,000M\Omega \cdot \mu$ F/C (C>0.33 μ F)
Solderability	Soldering temperature: $+235\pm 5^{\circ}C$ Immersion duration: 2 \pm 0.5sec	More than 90% of circumferential surface of lead wire shall be covered with new solder
Tensile Terminal Strength	Apply 1.0Kg (10N) for 10 \pm 1sec to the terminal in the axial direction and acting in a direction away from the body.	Shall be no abnormality
Bending Strength	Apply 0.5Kg for 2 cycles. Each cycle includes: 90° once, return to its initial position for 2~3 sec. and then to the opposite direction once.	Shall be no abnormality

EMI Suppression Capacitors Y2 Class 800VDC

MEY-800D Series

MERITEK

RELIABILTY AND TEST CONDITIONS

Item	Test Condition	Requirement																	
Damp Heat	Temperature: +40°C ± 2°C, Relative Humidity: 90%~95% Time: 56days; After test, let rest for 1.5±0.5hr at ordinary condition before making measurements.	Appearance : No Visible Damage Withstand Voltage: Within specified limits ΔC/C: ≤ ±5% of the value before test DF: ≤ 0.002 (0.2%) Max at 1KHz IR: ≥ 50% of the rated value																	
Dry Heat Resistance	Temperature: 110°C ± 2°C, Times: 16 +1/-0Hrs																		
Cold Resistance	Temperature: -40±3°C, Times: 2±1Hrs																		
Temperature Cycle	Test Temperature Cycle: Total 5 cycles. Each cycle includes <table border="1"> <thead> <tr> <th>Cycle</th> <th>Temperature</th> <th>Time</th> </tr> </thead> <tbody> <tr> <td>1</td> <td>+20±2°C</td> <td>3 min</td> </tr> <tr> <td>2</td> <td>-40±3°C</td> <td>30min</td> </tr> <tr> <td>3</td> <td>+20±2°C</td> <td>3 min</td> </tr> <tr> <td>4</td> <td>+110±2°C</td> <td>30min</td> </tr> <tr> <td>5</td> <td>+20±2°C</td> <td>3 min</td> </tr> </tbody> </table> After test, let rest for 1.5±0.5hr at ordinary condition before making measurements.		Cycle	Temperature	Time	1	+20±2°C	3 min	2	-40±3°C	30min	3	+20±2°C	3 min	4	+110±2°C	30min	5	+20±2°C
Cycle	Temperature	Time																	
1	+20±2°C	3 min																	
2	-40±3°C	30min																	
3	+20±2°C	3 min																	
4	+110±2°C	30min																	
5	+20±2°C	3 min																	
Vibration Resistance	Frequency change: 10~55~10Hz Vibration Distance: 1.5mm Test Direction: X, Y, Z Test Duration: 2+1/-0hrs each direction	Appearance : No mechanical Damage Connection: Shall be no short or open																	
Soldering Heat Resistance	Preheat Temperature: 100~120°C Preheat Duration: 60sec max Temperature increase by 3°C/sec max Soldering Temperature: +260±5°C Immersion Duration: 5±1sec Immersion Depth: 4±0.8mm from roots After test, allow it stay alone for 1.5±0.5hrs at ordinary condition before making measurements	Appearance: No Visible Damage Withstand Voltage: Within specified limits ΔC/C: ≤ ±3% of the value before test DF: ≤ 0.002 (0.2%) Max at 1KHz IR: ≥ 50% of the rated value																	
Endurance	Duration: 1,000 hours, Temperature: +110± 2°C Voltage: 1.7 times rated voltage. Once every hour the voltage increased to 1KVrms. For 0.1sec. The test voltage is applied to each capacitor individually through a Resistor of 47Ω±5%.	Appearance : No Visible Damage ΔC/C: ≤ ±10% of the value before test DF: ≤ 0.008 (0.8%) Max at 1KHz IR: ≥ 50% of the rated value																	
Humidity Resistance	Test Temperature: -40±2°C Test Humidity: 87% to 93% R.H. Test Voltage: rated voltage Test Duration: 500 hours After test, allow it stay alone for 1.5±0.5hrs at ordinary condition before making measurements	Appearance: No Visible Damage Withstand Voltage: Within specified limits ΔC/C: ≤ ±5% of the value before test DF: ≤ 0.002 (0.2%) Max at 1KHz IR: ≥ 50% of the rated value																	

Notes:

1. Ambient Temp: 15°C to 35°C, Relative Humidity (R.H.): 45% to 75%, Air Pressure: 86kpa to 106kpa
2. Operating Temperature: -40~110°C
3. Storage needs to be kept indoors at -10~+40°C and relative humidity of under 75% without any sudden temperature changes, direct sunlight and corrosive gas around
4. Do not apply and exceeding vibration, shock (dropping) and pressure

*Specifications subject to change without notice.