

# Multi-Function Varistor With 2 Remote Signal leads

TPT-S Series

MERITEK

## FEATURE

- Operating Temperature: -40°C ~ +85°C
- Max Continuous Operating Voltage: 50V<sub>AC</sub> ~ 550V<sub>AC</sub>
- High Surge Current rating: 50KA
- 2 Leads for Fault Indication
- Application in AC mains, Service Entrance, and Industrial Control
- Compliant with UL 1449 requirement
- UL/cUL Safety approved: Certification No: E326004



## PART NUMBERING SYSTEM

TPT   150   S   T2  
(1)   (2)   (3)   (4)



| No  | Item                      | Digit | Description                  | Series Reference                        |
|-----|---------------------------|-------|------------------------------|---|
| (1) | Meritek Series            | TPT   | Thermally Protected Varistor | With Remote Signal leads                |
| (2) | Max Operation AC Voltage  | 150   | 150: 150VAC                  | Max Continuous Operation Voltage (MCOV) |
| (3) | Terminal Type             | S     | S: Short tab type            | L: Long tab type                        |
| (4) | Signal Lead Configuration | T2    | T: Top side, 2 signal lead   | Location and No of single Lead          |

## ELECTRICAL CHARACTERISTICS

| Part Number | Max Continuous Operating Voltage |                    | Varistor Voltage At 1.0mA |        | Nominal Discharge Current<br>In 8/20us<br>(KA),15times | Max Discharge Current<br>Imax 8/20us<br>(KA),1times | Max DC Leakage Current<br>IL*<br>(uA) |
|-------------|----------------------------------|--------------------|---------------------------|--------|--|---|---------------------------------------|
|             | MCOV                             |                    | Vn min                    | Vn max |  |   |                                       |
|             | (V <sub>AC</sub> )               | (V <sub>DC</sub> ) | (V)                       | (V)    |  |   |                                       |
| TPT050S□    | 50                               | 65                 | 74                        | 90     | 20   | 50  | 15                                    |
| TPT060S□    | 60                               | 85                 | 90                        | 110    |  |   |                                       |
| TPT075S□    | 75                               | 100                | 108                       | 132    |  |   |                                       |
| TPT150S□    | 150                              | 200                | 222                       | 270    |  |   |                                       |
| TPT180S□    | 180                              | 225                | 256                       | 310    |  |   |                                       |
| TPT275S□    | 275                              | 350                | 410                       | 496    |  |   |                                       |
| TPT300S□    | 300                              | 385                | 427                       | 517    |  |   |                                       |
| TPT320S□    | 320                              | 415                | 459                       | 561    |  |   |                                       |
| TPT350S□    | 350                              | 460                | 504                       | 616    |  |   |                                       |
| TPT385S□    | 385                              | 505                | 558                       | 682    |  |   |                                       |
| TPT420S□    | 420                              | 560                | 612                       | 748    |  |   |                                       |
| TPT440S□    | 440                              | 585                | 644                       | 786    |  |   |                                       |
| TPT460S□    | 460                              | 615                | 675                       | 825    |  |   |                                       |
| TPT510S□    | 510                              | 670                | 738                       | 902    |  |   |                                       |
| TPT550S□    | 550                              | 745                | 819                       | 1001   |  |   |                                       |

\*Note: □: Tab size and lead configuration, Max DC leakage current measured at 75% of Varistor voltage

# Multi-Function Varistor With 2 Remote Signal leads

TPT-S Series

MERITEK

## DIMENSION and LEAD CONFIGURATION

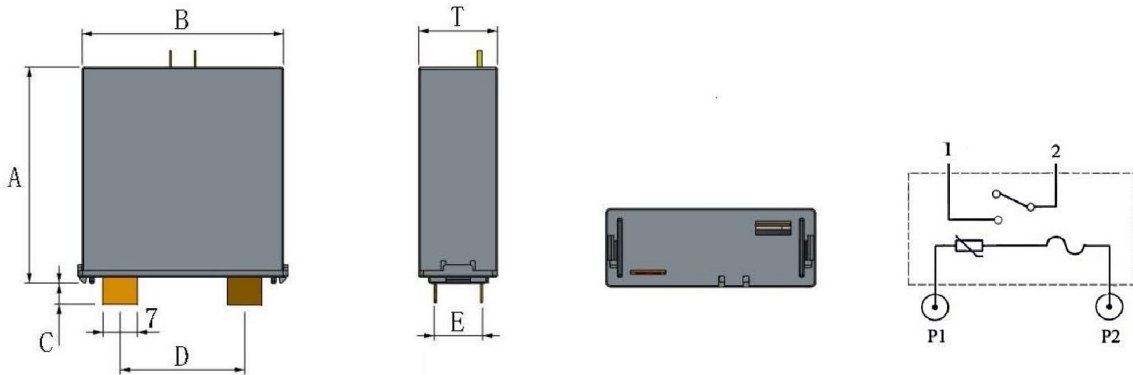

Unit: mm

| Series | A (±0.2) | B (±0.2) | C (±0.2) | D (±0.2) | T (±0.2) | E (±0.2) |
|--------|----------|----------|----------|----------|----------|----------|
| TPT-S  | 43.9     | 41.0     | 4.0      | 25.5     | 16.0     | 10.0     |

## SOLDERING RECOMMENDATION

### Wave Soldering

| Stage        | Condition      |
|--------------|----------------|
| 1 Preheating | <150sec        |
| 2 Soaking    | <100sec        |
| 3 Dwell Time | Dip Time ≤4sec |

### Iron Soldering

| Item  | Condition    |
|---|--------------|
| Iron Temperature  | 350°C (Max.) |
| Soldering Time  | 4sec (Max.)  |
| Space between Soldering Point and the Bottom of Product | 2mm (Min.)   |

### Wave Soldering Profile

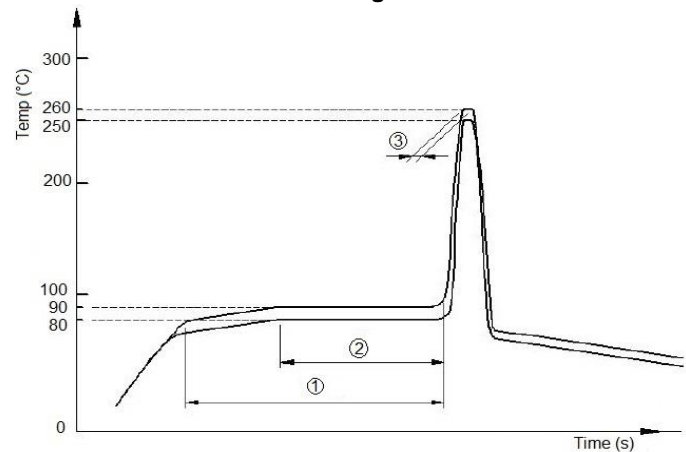

## PACKAGING SPECIFICATION

| Item         | Dimensions (mm) | Quantity              |
|--------------|-----------------|-----------------------|
| Plastic Tray | 250x180x22      | 12 PCS / Plastic Tray |
| Outside Box  | 270x250x220     | 288PCS / Carton       |

\*Specifications subject to change without notice.