

Transient Voltage Suppressors 3000W P600

3KP-E Series

MERITEK

FEATURE

- IEC 61000-4-2 ESD: $\pm 30\text{kV}$ (Air), $\pm 30\text{kV}$ (Contact)
- 3000W Peak Pulse Power (10/1000 μs), Repetitive Rate: 0.01%
- 5.0V to 220V Standoff Voltage
- Excellent Clamping Capability
- Glass Passivated Junction
- UL Flammability Classification Rating 94V-0
- UL Safety Approved Certification No: E223045

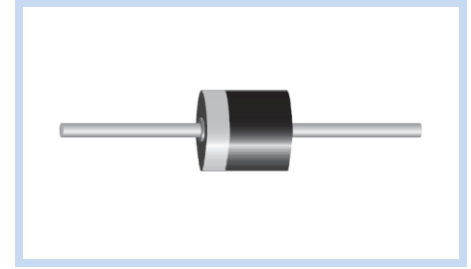

MECHANICAL DATA

- Case: P600/R-6, Molded Plastic
- Terminals: Solder Plated, Solderable per MIL-STD-750, Method 2026
- Polarity: Color Band Denotes Cathode End Except Bipolar

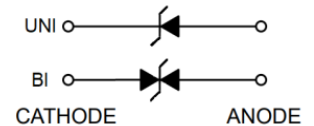

MAXIMUM RATINGS

Parameter	Symbol	Value	Unit
Peak Pulse Power Dissipation on 10/1000 μs waveform	P_{PPM}	Minimum 3000	W
Peak Pulse Current on 10/1000 μs waveform	I_{PPM}	See Table	A
Steady State Power Dissipation at $T_L = 75^\circ\text{C}$	P_D	7.0	W
Peak Forward Surge Current, 8.3ms Single Half Sine-wave Superimposed on Rated Load	I_{FSM}	300	A
Operating Junction And Storage Temperature Range	T_J, T_{STG}	-55 to +150	$^\circ\text{C}$
Typical Thermal Resistance Junction to Lead	$R_{\theta JL}$	8	$^\circ\text{C/W}$
Typical Thermal Resistance Junction to Ambient	$R_{\theta JA}$	40	$^\circ\text{C/W}$

Note:

1. $T_A = 25^\circ\text{C}$ ambient temperature unless otherwise specified.
2. Non-repetitive current pulse, and derated above $T_A = 25^\circ\text{C}$.
3. 8.3ms single half sine-wave, or equivalent square wave, Duty cycle = 4 pulses per minute maximum.

DIMENSIONS

P600/R-6	Min(mm)	Max(mm)
D	8.60	9.10
T	8.60	9.10
L	25.4	-
d	1.19	1.32

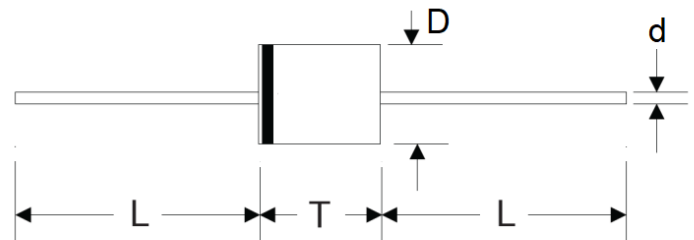

ELECTRICAL CHARACTERISTICS

Part Number		Working Reverse Voltage	Reverse Breakdown Voltage		Test Current	Max Reverse Leakage Current	Max Clamping Voltage	Reverse Surge Current
Uni-Polar	Bi-Polar	V _{RWM} (V)	V _{BR} Min(V)	V _{BR} Max(V)	I _T (mA)	I _R (uA) @ V _{RWM}	V _C (V) @ I _{PP}	I _{PP} (A) Max
3KP5.0A-E	3KP5.0CA-E	5.0	6.40	7.0	10	5000	9.2	326.1
3KP6.0A-E	3KP6.0CA-E	6.0	6.67	7.4	10	5000	10.3	291.3
3KP6.5A-E	3KP6.5CA-E	6.5	7.22	8.0	10	2000	11.2	267.9
3KP7.0A-E	3KP7.0CA-E	7.0	7.78	8.6	10	1000	12.0	250.0
3KP7.5A-E	3KP7.5CA-E	7.5	8.33	9.2	1	250	12.9	232.6
3KP8.0A-E	3KP8.0CA-E	8.0	8.89	9.8	1	150	13.6	220.6
3KP8.5A-E	3KP8.5CA-E	8.5	9.44	10.4	1	50	14.4	208.3
3KP9.0A-E	3KP9.0CA-E	9.0	10.0	11.1	1	20	15.4	194.8
3KP10A-E	3KP10CA-E	10	11.1	12.3	1	15	17.0	176.5
3KP11A-E	3KP11CA-E	11	12.2	13.5	1	2	18.2	164.8
3KP12A-E	3KP12CA-E	12	13.3	14.7	1	2	19.9	150.8
3KP13A-E	3KP13CA-E	13	14.4	15.9	1	2	21.5	139.5
3KP14A-E	3KP14CA-E	14	15.6	17.2	1	2	23.2	129.3
3KP15A-E	3KP15CA-E	15	16.7	18.5	1	2	24.4	123.0
3KP16A-E	3KP16CA-E	16	17.8	19.7	1	2	26.0	115.4
3KP17A-E	3KP17CA-E	17	18.9	20.9	1	2	27.6	108.7
3KP18A-E	3KP18CA-E	18	20.0	22.1	1	2	29.2	102.7
3KP20A-E	3KP20CA-E	20	22.2	24.5	1	2	32.4	92.6
3KP22A-E	3KP22CA-E	22	24.4	26.9	1	2	35.5	84.5
3KP24A-E	3KP24CA-E	24	26.7	29.5	1	2	38.9	77.1
3KP26A-E	3KP26CA-E	26	28.9	31.9	1	2	42.1	71.3
3KP28A-E	3KP28CA-E	28	31.1	34.4	1	2	45.4	66.1
3KP30A-E	3KP30CA-E	30	33.3	36.8	1	2	48.4	62.0
3KP33A-E	3KP33CA-E	33	36.7	40.6	1	2	53.3	56.3
3KP36A-E	3KP36CA-E	36	40.0	44.2	1	2	58.1	51.6
3KP40A-E	3KP40CA-E	40	44.4	49.1	1	2	64.5	46.5
3KP43A-E	3KP43CA-E	43	47.8	52.8	1	2	69.4	43.2
3KP45A-E	3KP45CA-E	45	50.0	55.3	1	2	72.7	41.3
3KP48A-E	3KP48CA-E	48	53.3	58.9	1	2	77.4	38.8
3KP51A-E	3KP51CA-E	51	56.7	62.7	1	2	82.4	36.4
3KP54A-E	3KP54CA-E	54	60.0	66.3	1	2	87.1	34.4
3KP58A-E	3KP58CA-E	58	64.4	71.2	1	2	93.6	32.1
3KP60A-E	3KP60CA-E	60	66.7	73.7	1	2	96.8	31.0
3KP64A-E	3KP64CA-E	64	71.1	78.6	1	2	103	29.1
3KP70A-E	3KP70CA-E	70	77.8	86.0	1	2	113	26.5
3KP75A-E	3KP75CA-E	75	83.3	92.1	1	2	121	24.8
3KP78A-E	3KP78CA-E	78	86.7	95.8	1	2	126	23.8
3KP85A-E	3KP85CA-E	85	94.4	104	1	2	137	21.9
3KP90A-E	3KP90CA-E	90	100	111	1	2	146	20.5
3KP100A-E	3KP100CA-E	100	111	123	1	2	162	18.5
3KP110A-E	3KP110CA-E	110	122	135	1	2	177	16.9
3KP120A-E	3KP120CA-E	120	133	147	1	2	193	15.5
3KP130A-E	3KP130CA-E	130	144	159	1	2	209	14.4
3KP150A-E	3KP150CA-E	150	167	185	1	2	243	12.3
3KP160A-E	3KP160CA-E	160	178	197	1	2	259	11.6
3KP170A-E	3KP170CA-E	170	189	209	1	2	275	10.9
3KP180A-E	3KP180CA-E	180	201	222	1	2	292	10.3
3KP190A-E	3KP190CA-E	190	211	233	1	2	308	9.7
3KP200A-E	3KP200CA-E	200	224	247	1	2	324	9.3
3KP210A-E	3KP210CA-E	210	237	263	1	2	340	8.8
3KP220A-E	3KP220CA-E	220	246	272	1	2	356	8.4

Note: T_A = 25°C ambient temperature unless otherwise specified.

CHARACTERISTIC CURVES

Peak Pulse Power Rating Curve

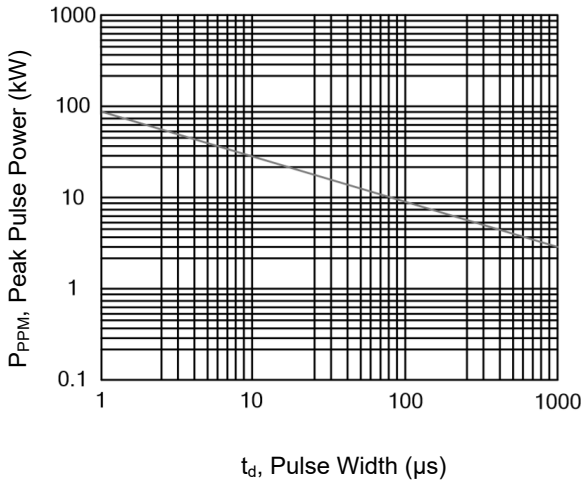

Pulse Derating Curve

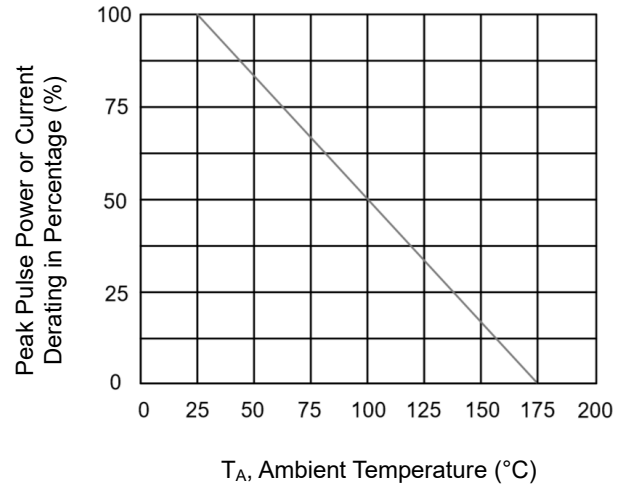

Pulse Waveform

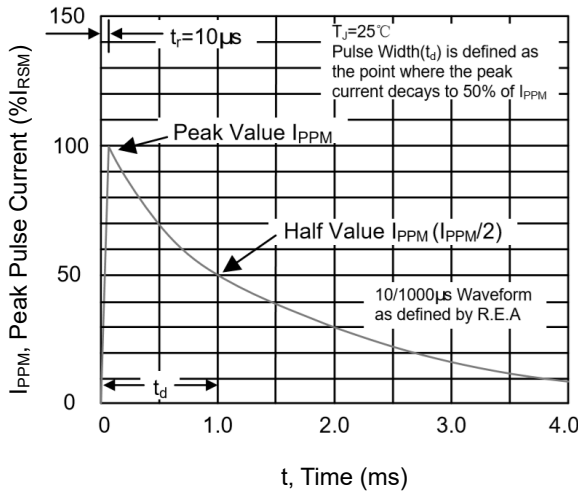

Typical Junction Capacitance

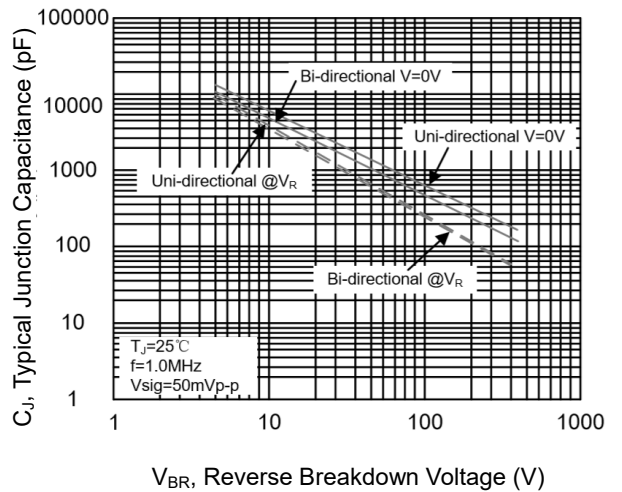

Steady State Power Dissipation Derating Curve

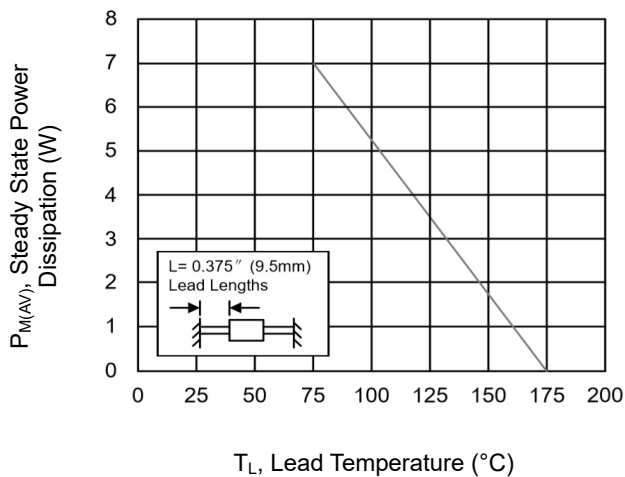

Maximum Non-Repetitive Forward Surge Current Uni-Directional Only

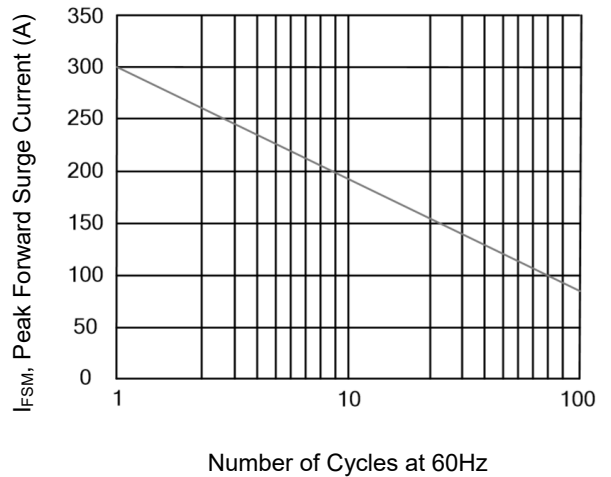

*Specifications subject to change without notice.