

Schottky Barrier Rectifier

3A, 20~200V SMA-F

SK32AF to SK320AF

MERITEK

FEATURE

- Low Power Loss, High Efficiency
- Ideally Suited for Automated Assembly Processes
- Application: Power Management Systems, Voltage Regulation
- Flammability Classification 94V-0

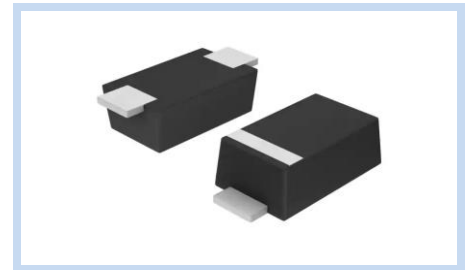

MECHANICAL DATA

- Case: Sma-F, Molded Plastic
- Terminals: Solderable Per Mil-Std-750, Method 2026
- Polarity: Color Band Denotes Cathode End



MAXIMUM RATINGS (TA=25 °C unless otherwise noted)

Parameter	Symbol	SK32 AF	SK33 AF	SK34 AF	SK35 AF	SK36 AF	SK38 AF	SK310 AF	SK315 AF	SK320 AF	Unit	
Maximum Recurrent Peak Reverse Voltage	V _{RRM}	20	30	40	50	60	80	100	150	200	V	
Maximum RMS Voltage	V _{RMS}	14	21	28	35	42	56	70	105	140	V	
Maximum DC Blocking Voltage	V _{DC}	20	30	40	50	60	80	100	150	200	V	
Maximum Average Forward Rectified Current	I _F	3.0									A	
Peak Forward Surge Current (JEDEC method)	I _{FSM}	80.0									A	
Maximum Forward Voltage at 3.0A	V _F	0.55	0.70		0.85		0.95			V		
Maximum Reverse Current at rated DC Blocking Voltage	I _R	0.5			0.3			mA				
		5.0			3.0							
Typical Thermal Resistance	R _{θJA}	80.0									°C/W	
Operating Junction Temperature	T _J	-65 ~ 125					-65 ~ 150					°C
Storage Temperature	T _{stg}	-65 ~ 150									°C	

Notes: 1. Pulse test 300us pulse width, 2%duty cycle 2.Mounted on P.C.B with 0.2x0.2"(5.0x5.0mm) copper pad areas.

Schottky Barrier Rectifier

3A, 20~200V SMA-F

SK32AF to SK320AF

MERITEK

CHARACTERISTIC CURVES

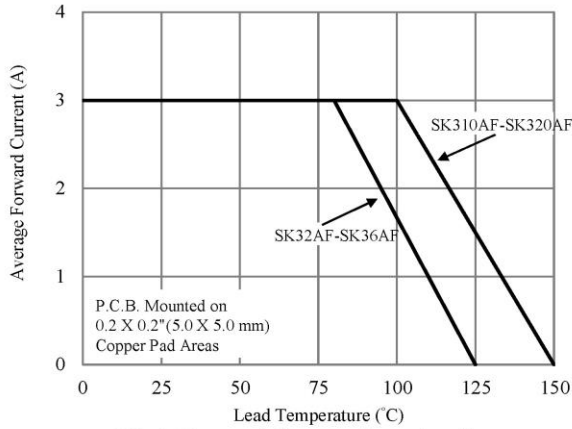

Fig.1-Forward Current Derating Curve



Fig.2-Maximum Non-Repetitive Peak Forward Surge Current

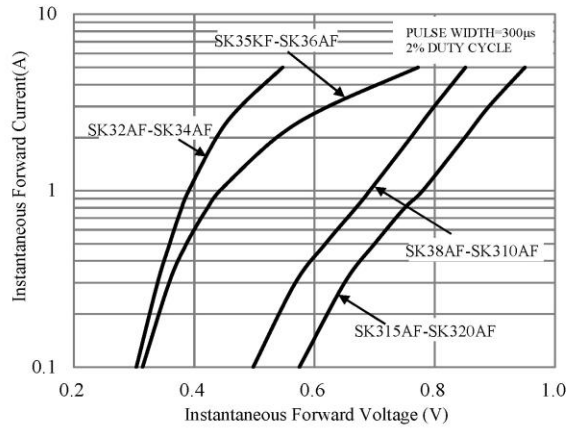

Fig.3-Typical Instantaneous Forward Characteristics

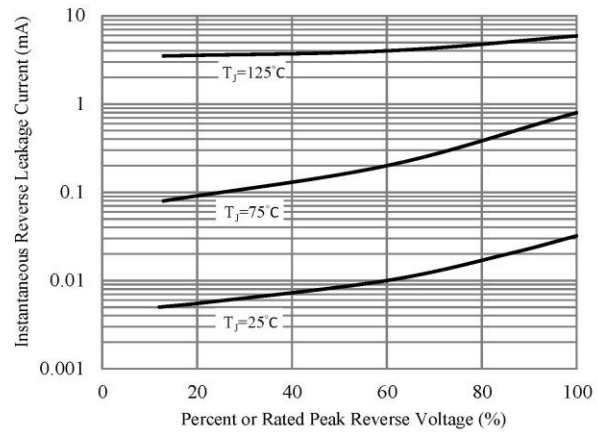
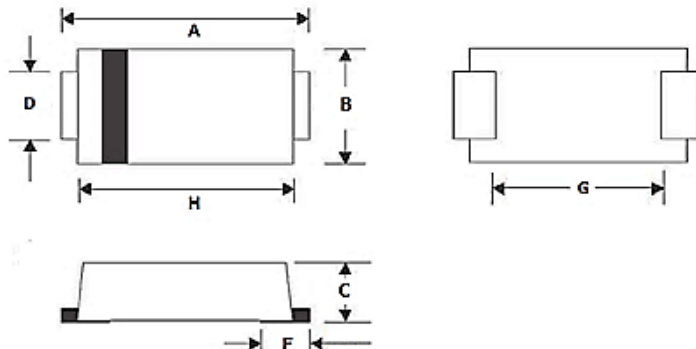

Fig.4-Typical Reverse Leakage Characteristics

DIMENSIONS

Item	Min (mm)	Max (mm)
A	4.85	5.15
B	2.40	2.80
C	0.90	1.20
D	1.35	1.65
F	0.95	1.25
G	MIN 2.35	
H	3.65	4.05



*Specifications subject to change without notice.