

N-Channel MOSFET

500V 7.5A 107W TO-252

MFT50N7A5T252

MERITEK

FEATURE

- Operating temperature: -55°C ~ 175°C
- Super high density cell design for low on state resistance
- High power and current handling capability

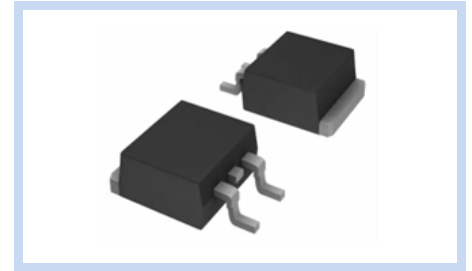

MAXIMUM RATINGS

Parameter	Symbol	Value	Unit
Drain-Source Voltage	V_{DS}	500	V
Gate-Source Voltage	V_{GS}	±30	V
Drain Current – Continuous ($T_C = 25^\circ\text{C}$)	I_D	7.5	A
Drain Current – Continuous ($T_C = 100^\circ\text{C}$)	I_D	4.7	A
Drain Current – Pulsed	I_{DM}	30	A
Power Dissipation ($T_C = 25^\circ\text{C}$)	P_D	107	W
Power Dissipation (Derate above 25°C)		0.85	W/°C
Single Pulsed Avalanche Energy	E_{AS}	196	mJ
Single Pulsed Avalanche Current	I_{AS}	7.5	A
Operating and Storage Temperature Range	T_J, T_{STG}	-55 to 175	°C

THERMAL CHARACTERISTICS

Parameter	Symbol	Value	Unit
Thermal Resistance, Junction to Case	$R_{\theta JC}$	1.4	°C/W
Thermal Resistance, Junction to Ambient	$R_{\theta JA}$	50	°C/W

DIMENSIONS

Item	Min (mm)	Max (mm)
A	2.20	2.40
A1	0.45	0.89
b	0.50	0.90
b1	4.95	5.59
C	0.40	0.61
D	5.40	6.63
E	6.05	7.10
e	1.98	2.59
H	8.80	10.6
L	0.25	--
L1	0.50	1.20
L2	0.70	1.78

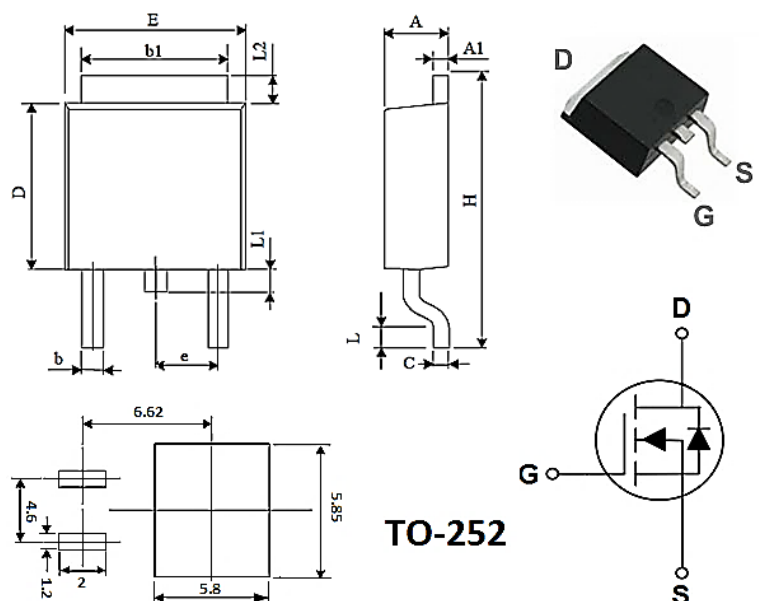

N-Channel MOSFET

500V 7.5A 107W TO-252

MFT50N7A5T252

MERITEK

ELECTRICAL CHARACTERISTICS

Static Characteristics	Conditions	Symbol	Min	Typ.	Max	Unit
Drain-Source Breakdown Voltage	$V_{GS}=0V, I_D=250\mu A$	BV_{DSS}	500	--	--	V
Gate Threshold Voltage	$V_{GS}=V_{DS}, I_D=250\mu A$	$V_{GS(th)}$	2	--	4	V
Zero Gate Voltage Drain Current	$V_{DS}=500V, V_{GS}=0V$	I_{DSS}	--	--	1	μA
Gate Leakage Current, Forward	$V_{DS}=0V, V_{GS}=30V$	I_{GSSF}	--	--	100	nA
Gate Leakage Current, Reverse	$V_{DS}=0V, V_{GS}=-30V$	I_{GSSR}	--	--	-100	
Drain-Source On-Resistance	$V_{GS}=10V, I_D=3.8A$	$R_{DS(ON)}$	--	0.68	0.85	Ω
Dynamic Characteristics	Conditions	Symbol	Min	Typ.	Max	Unit
Total Gate Charge	$V_{DS}=400V, V_{GS}=10V, I_D=7A$	Q_g	--	25	--	nC
Gate-Source Charge		Q_{gs}	--	5	--	
Gate-Drain Charge		Q_{gd}	--	6	--	
Turn-On Delay Time	$V_{DD}=250V, R_{GEN}=9.1\Omega, I_D=7A, V_{GS}=10V$	$T_{d(on)}$	--	20	--	nS
Rise Time		T_r	--	5	--	
Turn-Off Delay Time		$T_{d(off)}$	--	38	--	
Fall Time		T_f	--	4	--	
Input Capacitance	$V_{DS}=25V, V_{GS}=0V, F=1.0MHz$	C_{iss}	--	1580	--	pF
Output Capacitance		C_{oss}	--	125	--	
Reverse Transfer Capacitance		C_{rss}	--	15	--	
Drain-Source Diode Characteristics	Conditions	Symbol	Min	Typ.	Max	Unit
Drain-Source Diode Forward Current	--	I_S	--	--	7	A
Drain-Source Diode Forward Voltage	$I_S=15A, V_{GS}=0V$	V_{SD}	--	--	1.5	V

Note:

1. Repetitive Rating : Pulse width limited by maximum junction temperature
2. Device Mounted on FR4 Board, $T \leq 10sec$
3. Pulse Test : Pulse Width < 300 μs , Duty Cycle < 2%
4. Guaranteed by design, not subject to production testing.
5. $L=7mH, I_{AS}=7.5A, V_{DD}=50V, R_G=25\Omega$, Starting $T_J=25^\circ C$

Switching Time Waveform

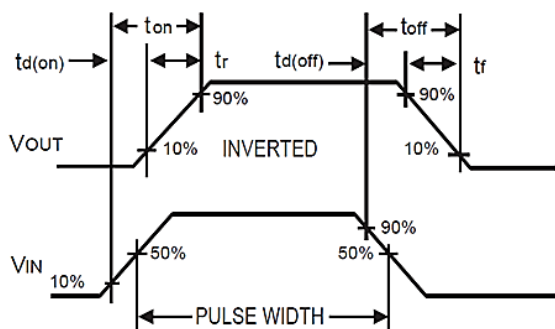

Switching Test Circuit

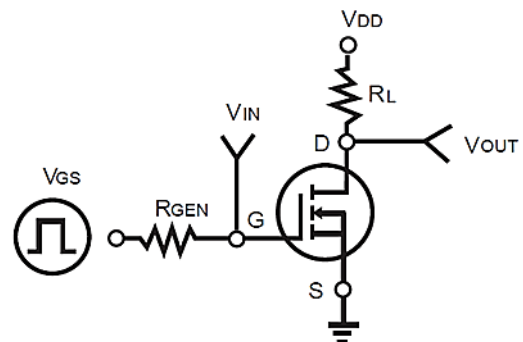

CHARACTERISTIC CURVES

Output Characteristics

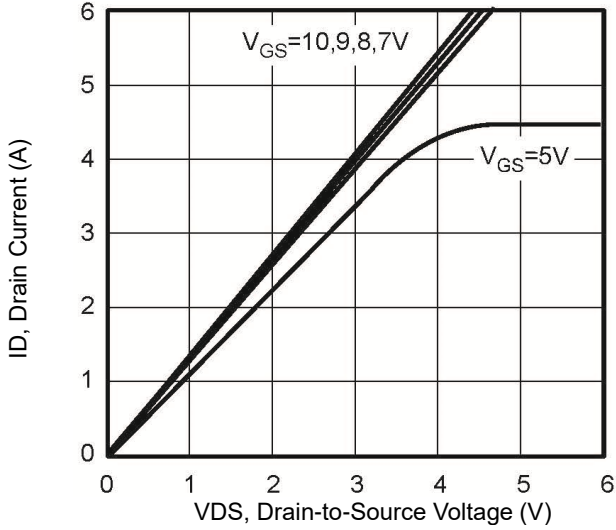

Transfer Characteristics

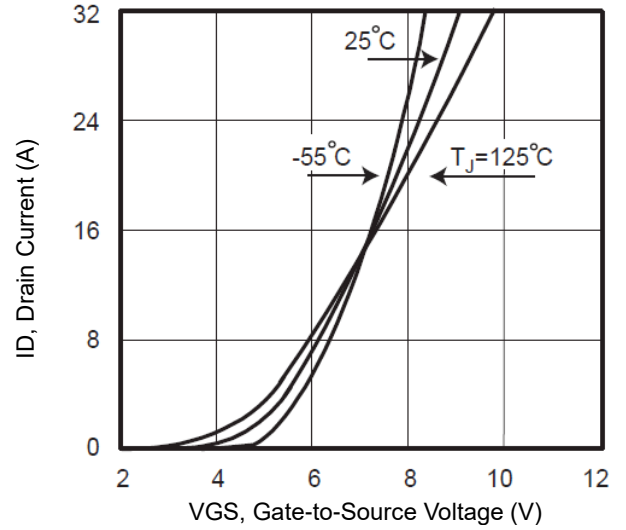

Capacitance

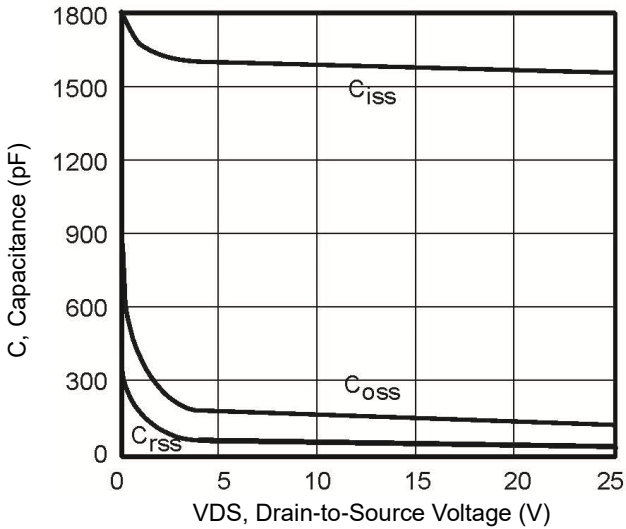

On-Resistance vs. T_J

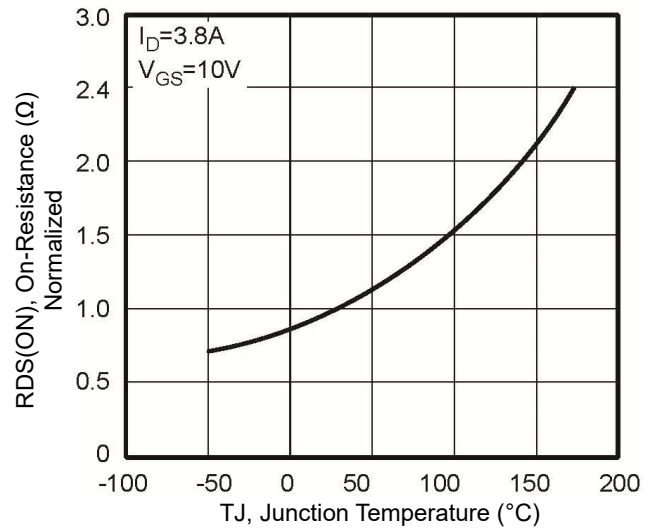

Gate Threshold Variation vs. T_J

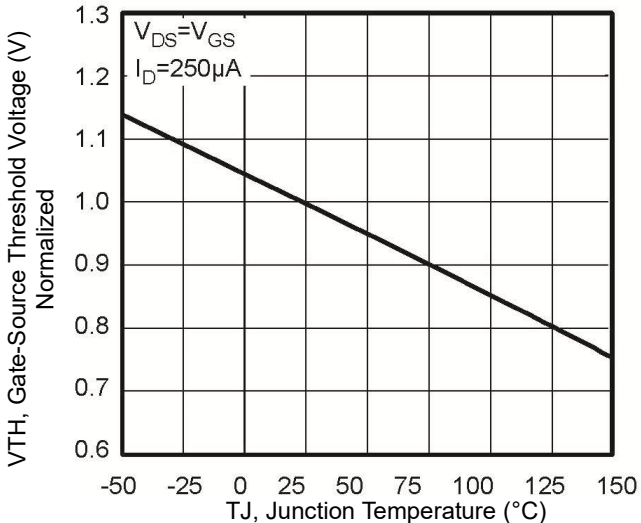

Body Diode Forward Voltage Variation vs. I_S

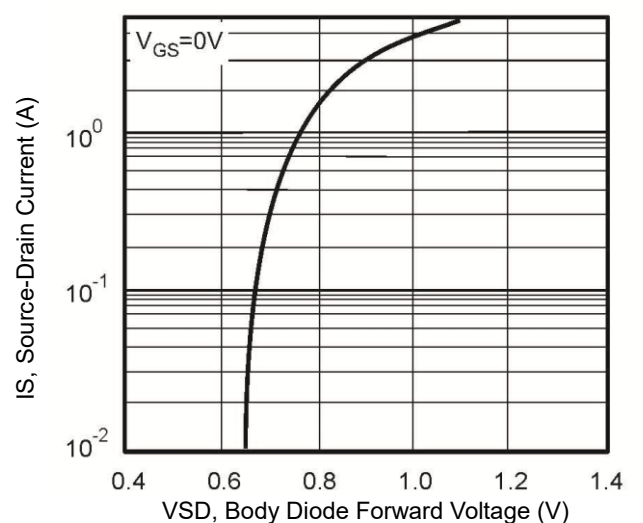

N-Channel MOSFET

500V 7.5A 107W TO-252

MFT50N7A5T252

MERITEK

CHARACTERISTIC CURVES

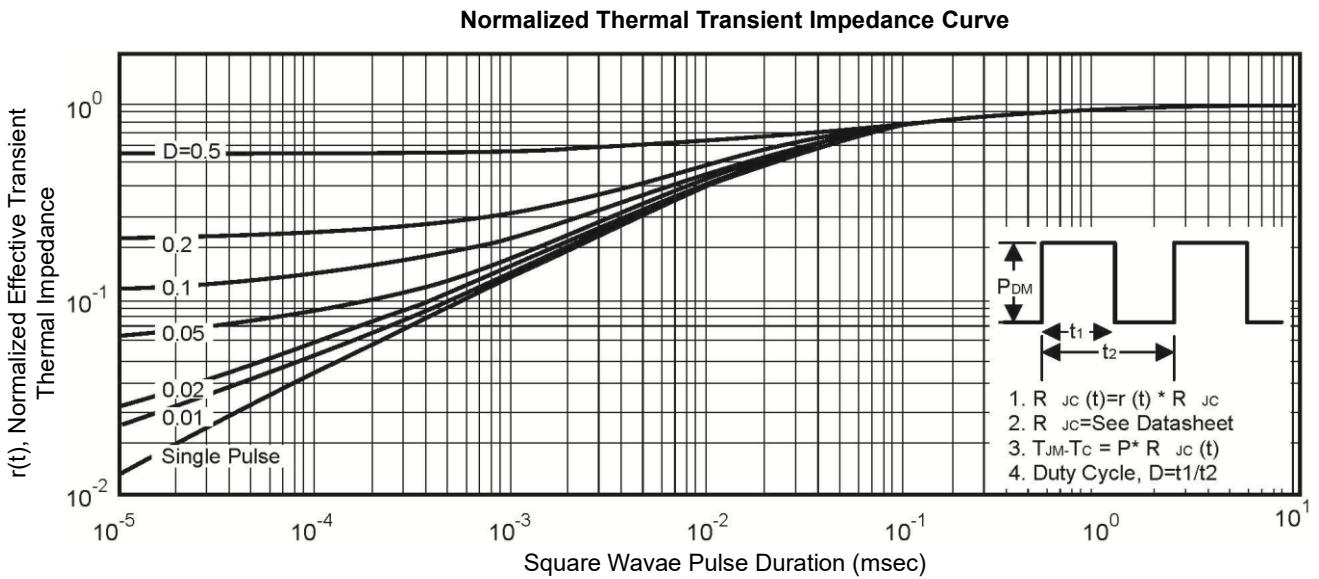
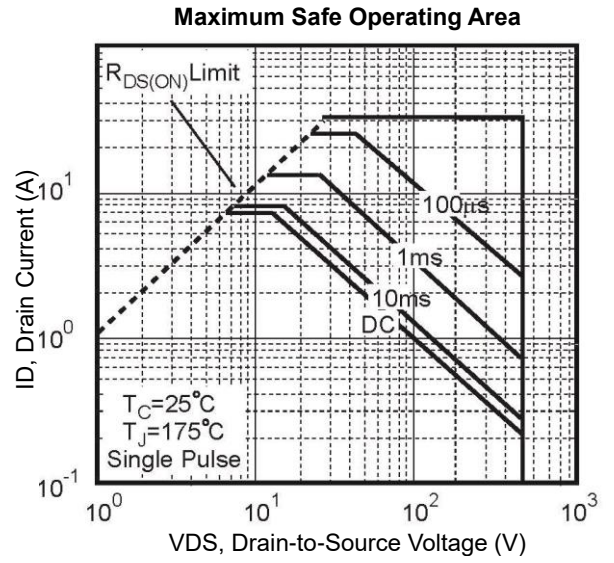
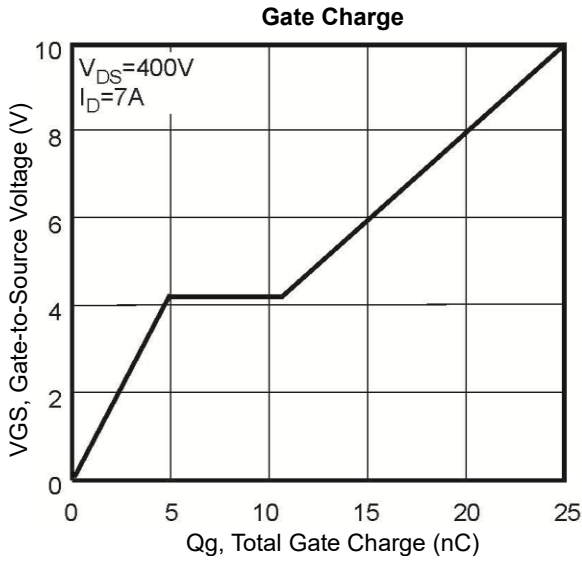

*Specifications subject to change without notice.