

Metal Alloy Chip Resistor SMT Shunt Type

MLRS Series

MERITEK

FEATURE

- Operation Temperature: -65~+170°C
- High precision current sensing and voltage division
- Low-Resistance and TCR
- Excellent Anti-Surge Capability
- AEC-Q200 qualified
- Applications: Power modules, High current Power Supply, Measuring instrument, Battery management system, Automotive



PART NUMBERING SYSTEM

MLRS 2512 6 M30 F
(1) (2) (3) (4) (5)



No	Item	Code	Description	Series Reference
(1)	Meritek Series	MLRS	Metal Alloy Chip Resistor	Shunt Type SMT
(2)	Size Code	2512	2512: 3.2x1.6x 1.2mm	1206, 3920, 5930
(3)	Rated Power	6	6: 6W	B:2.5W, 2:2W; 5:5W; 8:8W; 12:12W; 15:15W
(4)	Resistance	M30	M30: 0.30 mΩ	M30: 0.30mΩ ~ 05M: 5mΩ
(5)	Tolerance	F	F:±1%	G: ±2%, J: ±5%

DIMENSIONS AND LAND PATTERN RECOMMENDATION

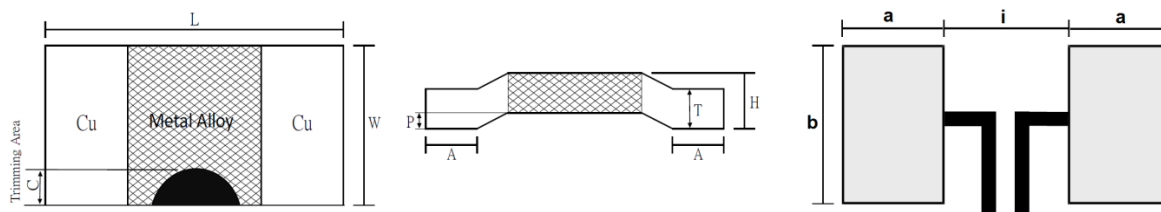

Size	Resistance (mR)	L ± 0.30	W ± 0.30	H ± 0.15	T ± 0.15	A	C Max	P ± 0.10	a	b	i
1206	0.30~ 1.00	3.20	1.65	See Table Below	See Table Below	0.80±0.2	-	-	2.10	1.80	1.40
2512	0.30~ 5.00	6.50	3.25			0.90±0.2	0.40	0.35	1.80	3.40	3.80
3920	0.20~ 5.00	10.20	5.20			1.80±0.3	0.60	0.50	2.70	6.20	5.60
5930	0.20~ 3.00	15.00	7.75			4.20±0.2	1.00	0.50	5.20	8.75	5.60

Unit: mm

Metal Alloy Chip Resistor SMT Shunt Type

MLRS Series

MERITEK

ELECTRICAL CHARACTERISTICS

Size	Resistance F(1%),G(2%),J(5%)	Power Rating at 70°C	T.CR.	Max. Rating Current	Max Overload Current	H ± 0.15	T ± 0.15	Material
	(mΩ)	(W)	(ppm/°C)	(A)	(A)	(mm)	(mm)	
1206	0.30	2	≤±300	81.60	182.57	1.2	-	MnCuSn
	0.50	2	≤±200	63.24	141.42	0.9	-	MnCuSn
	1.00	2	≤±150	44.72	100.00	0.9	-	MnCu
2512	0.25	6	≤±200	154.42	346.41	1.35	1.00	MnCuSn
	0.30	6	≤±150	141.42	316.22	1.17	0.82	MnCuSn
	0.50	6	≤±115	109.54	244.94	1.07	0.72	MnCu
	0.75	5	≤±115	81.65	182.57	0.95	0.60	MnCu
	1.00	5	≤±100	70.71	158.11	0.73	0.38	MnCu
	2.00	5	≤±50	50.00	111.80	0.96	0.61	FeCrAl
	3.00	4	≤±50	36.51	81.65	0.76	0.41	FeCrAl
	4.00	3	≤±50	27.38	61.23	0.66	0.31	FeCrAl
3920	0.20	12	≤±200	244.94	547.72	1.98	1.48	MnCuSn
	0.30	10	≤±150	182.57	408.24	1.92	1.42	MnCu
	0.50	9	≤±75	134.16	300.00	1.36	0.86	MnCu
	1.00	8	≤±50	89.44	200.00	0.92	0.42	FeCrAl
	1.00	7	≤±50	83.66	187.08	1.87	1.37	MnCu
	1.50	7	≤±50	68.31	152.75	1.46	0.96	FeCrAl
	2.00	6	≤±50	54.77	122.47	1.19	0.69	FeCrAl
	3.00	5	≤±50	40.82	91.28	0.94	0.44	FeCrAl
	4.00	4	≤±50	31.62	70.71	0.85	0.35	FeCrAl
	5.00	3	≤±50	24.49	54.77	0.85	0.35	FeCrAl
5930	0.20	15	≤±100	273.86	612.37	1.92	1.42	MnCu
	0.30	10	≤±100	182.57	408.24	1.44	0.94	MnCu
	0.50	8	≤±75	126.49	282.84	1.08	0.58	MnCu
	1.00	8	≤±50	89.44	200.00	1.37	0.87	FeCrAl
	2.00	7	≤±50	59.16	132.28	0.95	0.46	FeCrAl
	3.00	5	≤±50	40.82	91.28	0.90	0.40	FeCrAl

Notes: Power rating is guaranteed when terminal temperature of resistor is below 70°C
Operating Temperature Range: -65~+170°C, Storage Temperature: 25±°C, Humidity: 60±20%

Metal Alloy Chip Resistor SMT Shunt Type

MLRS Series

MERITEK

RELIABILITY TEST CONDITION AND REQUIREMENT

Item	Test Method	Conditon	Requirements
Temperature Coefficient of Resistance (T.C.R)	JIS-C-5201-1 4.8 IEC-60115-1 4.8	At 25°C /+125°C, 25°C is the reference temperature	Refer to electrical specifications
Short Time Overload	JIS-C-5201-1 4.13 IEC-60115-1 4.13	Apply 5 times of rated power for 5 seconds for following size: 1206, 2512, 3920, 5930:	$\Delta R/R1 \leq \pm(1.0\%+0.0005\Omega)$
High Temperature Exposure (Storage)	MIL-STD-202 Method 108	1000 hrs. at T=170°C. Unpowered. Measurement at 24±4 hours after test conclusion.	$\Delta R/R1 \leq \pm(1.0\%+0.0005\Omega)$
Temperature Cycling	JESD22 Method JA-104	1000 Cycles (-55°C to +155°C) Measurement at 24±4 hours after test conclusion. 30min maximum dwell time at each temperature extreme.	$\Delta R/R1 \leq \pm(1.0\%+0.0005\Omega)$
Biased Humidity	MIL-STD-202 Method 103	1,000 hours; 85°C / 85% RH, 10% of operating power. Measurement at 24±4 hours after test conclusion.	$\Delta R/R1 \leq \pm(1.0\%+0.0005\Omega)$
Operation Life	MIL-STD-202 Method 108	Condition D Steady State TA=125°C at derated power. Measurement at 24±4 hours after test conclusion.	$\Delta R/R1 \leq \pm(1.0\%+0.0005\Omega)$
Moisture Resistance	MIL-STD-202, Method 106	Humidity of 90~98% and a temperature of 25°C / 65°C ,10 cycles	$\Delta R/R1 \leq \pm(1.0\%+0.0005\Omega)$
Mechanical Shock	MIL-STD-202 Method 213	Test ½ Sine Pulse, Peak value: 100g, normal duration: 6ms, Velocity change:12.3ft/sec.	$\Delta R/R1 \leq \pm(1.0\%+0.0005\Omega)$
Vibration	MIL-STD-202 Method 204	5 g's for 20 min., 12 cycles each of 3 orientations. Note: Test from 10-2000Hz	$\Delta R/R1 \leq \pm(1.0\%+0.0005\Omega)$
Board Flex	AEC Q200-005	Beading once for 60 seconds ,2mm	$\Delta R/R1 \leq \pm(1.0\%+0.0005\Omega)$
Solderability	J-STD-002	(1) 4 hrs 155°C dry heat (2) 245±5°C 3 sec.	>95% coverage (electrode area)

Notes: All reliability test should follow Derating curve, terminal temperature of component should be below 70°C.

Footprint size, solder insufficient, excessive solder, solder void and component shifted will affect the resistance accuracy after IR reflow. Circuit calibration is a must to be done by functional test.

POWER DERATING CURVE

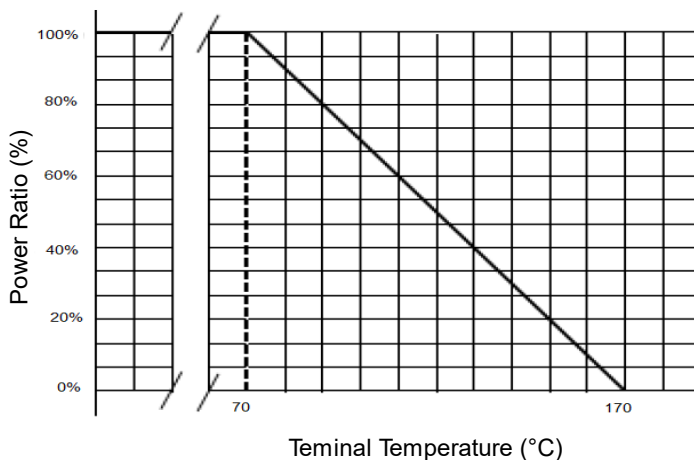

CHARACTERISTICS CURVES

Pulse Power – 1206 035mR

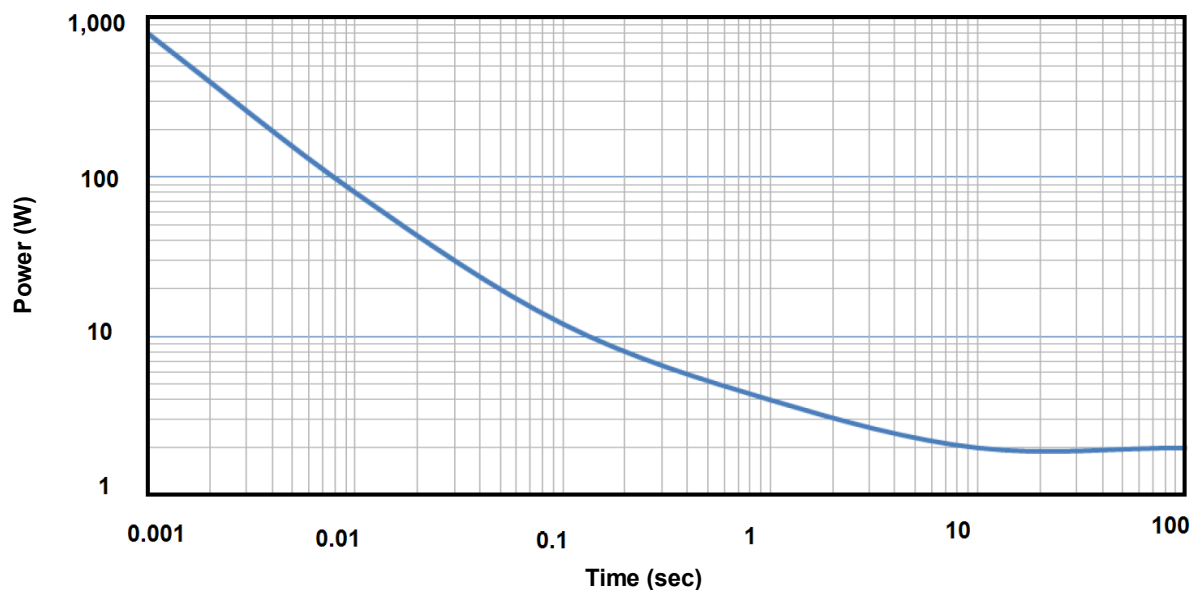

Pulse Power – 2512

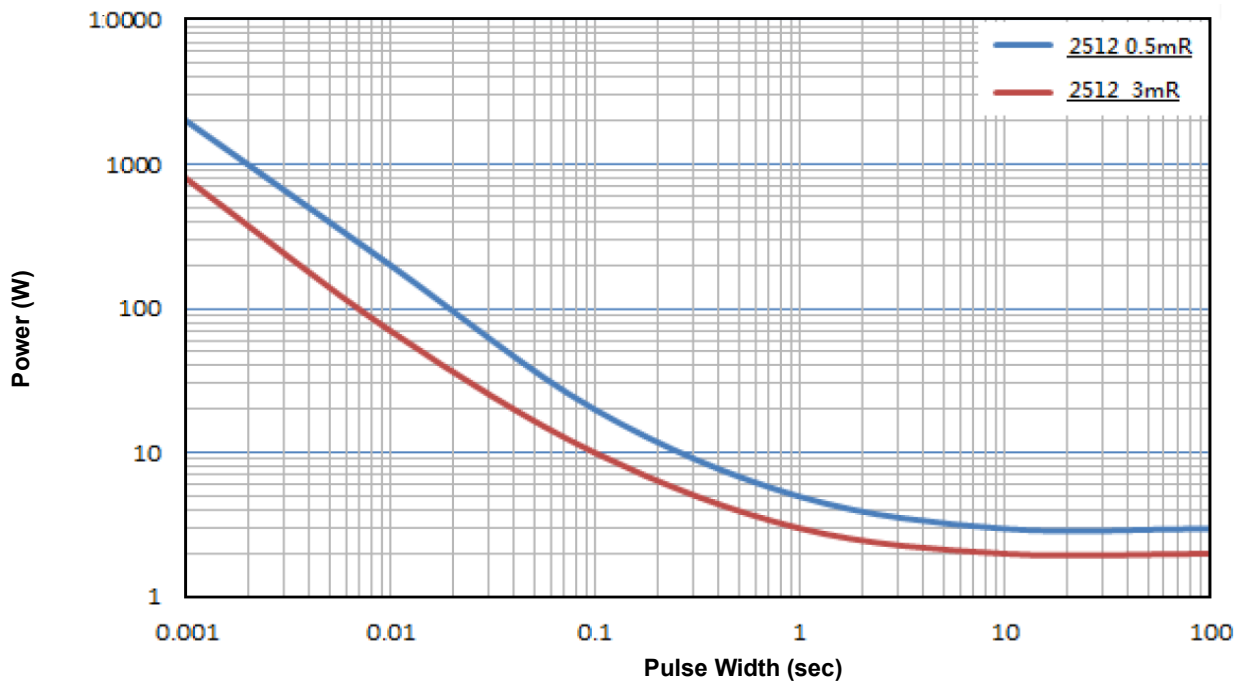

CHARACTERISTICS CURVES

Pulse Power - 3920

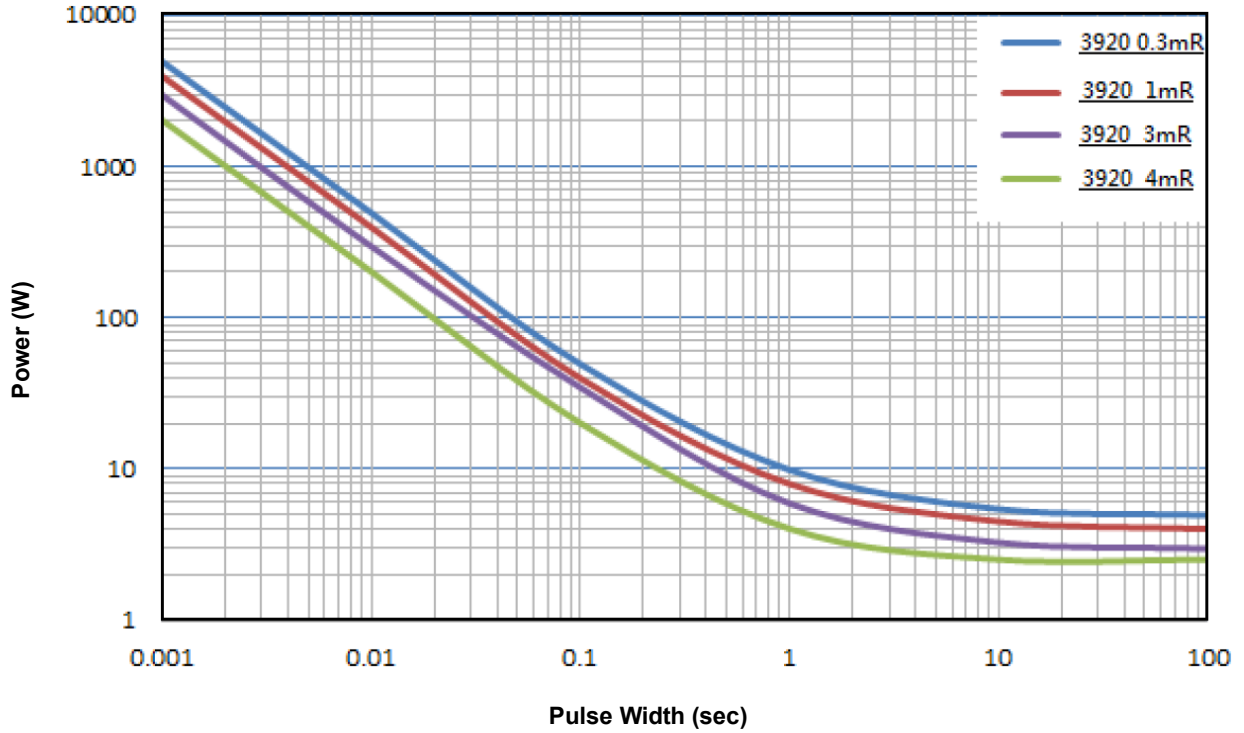

Pulse Power - 5930

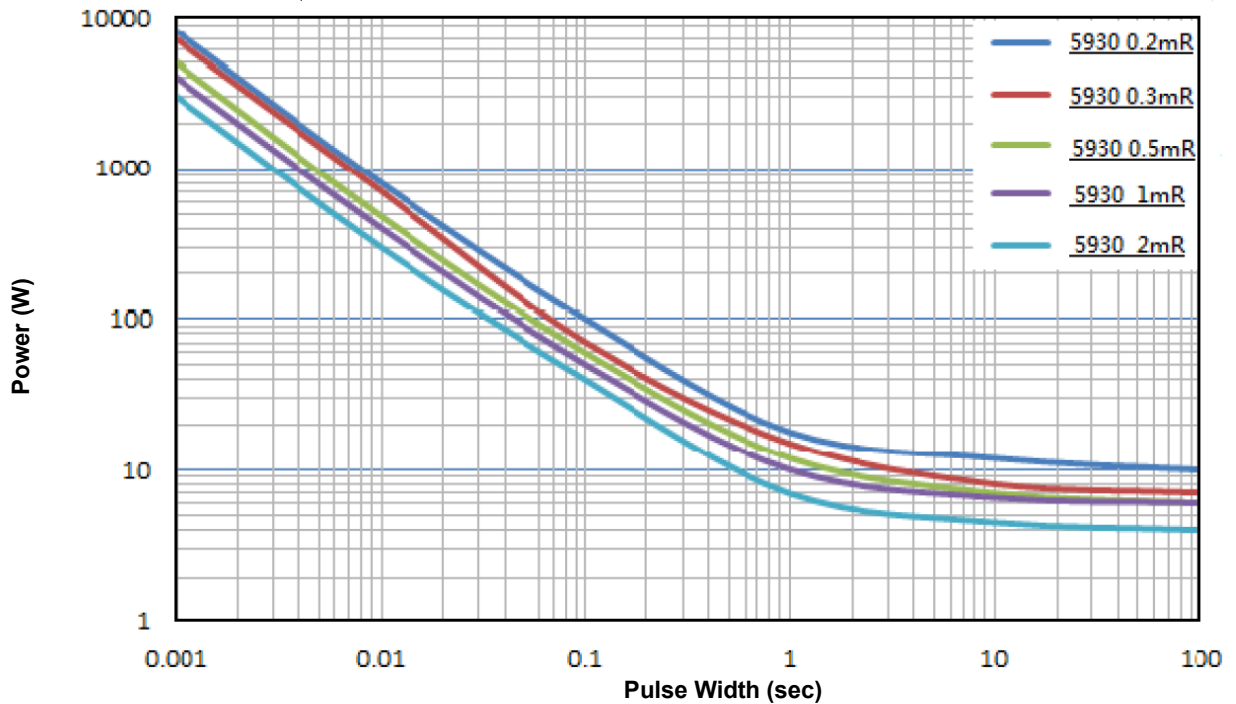

Metal Alloy Chip Resistor SMT Shunt Type

MLRS Series

MERITEK

SOLDERING RECOMMENDATION

Reflow Condition		
Pre Heat	Temp. Min $T_{s(min)}$	150°C
	Temp. Max $T_{s(max)}$	180°C
	Time (min. to max.) (t_s)	60s ~ 120s
Average ramp up rate (T_L) to peak		3°C/s max.
$T_{s(max)}$ to T_L (Ramp-up rate)		3°C/s max.
Reflow	Temp. (T_L)	230°C
	Time (min. to max.) (t_L)	40s max.
Peak Temperature (T_P)		250°C
Time within 5°C of T_P (t_p)		10s
Ramp-down Rate		6°C/s

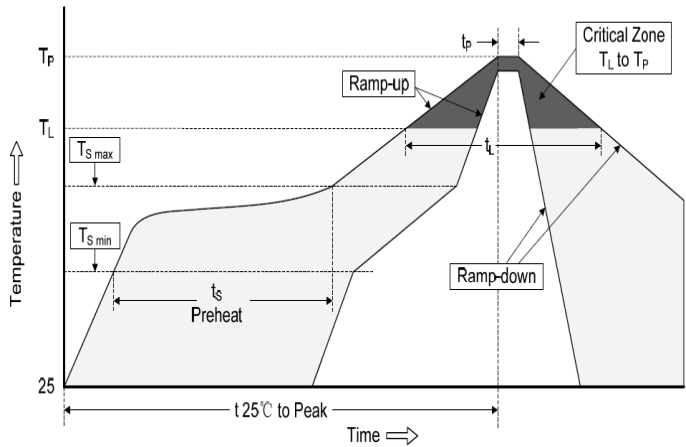

PACKAGING SPECIFICATIONS

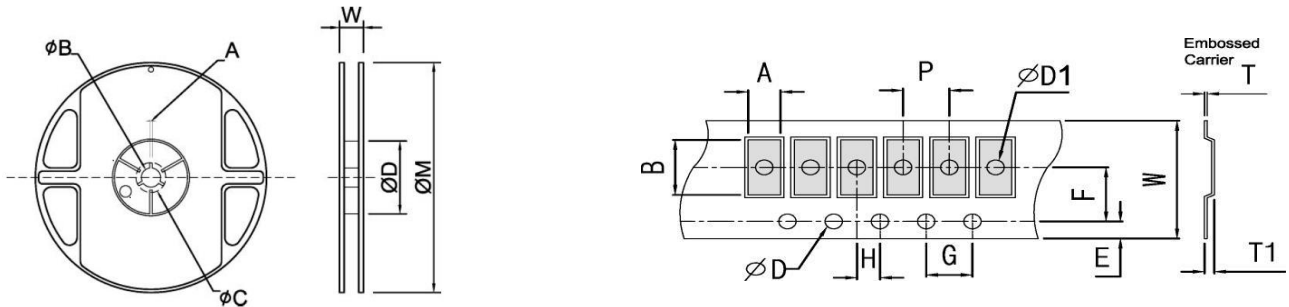

Size	Reel Dimension (mm)								
	Quantity / Type		Reel Diameter	A ±0.5	φB ±0.5	φC ±0.5	φD ±0.5	W ±0.5	φM ±1.0
1206	2,000 / Reel	Plastic	7"	2	13.0	17.7	60.0	12.0	178
2512	4,000 / Reel	Plastic	10"	2	13.0	17.7	62.0	16.5	250
3920	3,000 / Reel	Plastic	13"	2.5	13.5	17.7	99.0	20.7	330
5930	2,000 / Reel	Plastic	13"	2.5	13.5	17.7	99.0	29.4	330

Size	Plastic Tape Dimension (mm)										
	Resistance (mΩ)	W ±0.30	P ±0.10	E ±0.10	F ±0.10	φD ±0.05	G ±0.10	H ±0.10	A ±0.10	B ±0.10	T1 ±0.10
1206	0.3, 0.5, 1.0	8.0	4.0	1.75	3.5	1.55	4.0	2.0	1.88	3.56	1.40
	0.3, 0.5, 0.75, 2	12.0	4.0	1.75	5.5	1.55	4.0	2.0	3.55	6.75	1.40
2512	1, 3	12.0	4.0	1.75	5.5	1.55	4.0	2.0	3.55	6.75	1.10
	4, 5	12.0	4.0	1.75	5.5	1.55	4.0	2.0	3.55	6.75	0.80
3920	0.2, 0.3, 0.5, 2	16.0	8.0	1.75	7.5	1.55	4.0	2.0	5.5	10.8	1.97
	1, 3, 4, 5	16.0	8.0	1.75	7.5	1.55	4.0	2.0	5.5	10.8	1.25
5930	0.2, 0.3, 1	24.0	12.0	1.75	11.5	1.55	4.0	2.0	8.3	15.4	2.30
	0.5, 2, 3	24.0	12.0	1.75	11.5	1.55	4.0	2.0	8.3	15.4	1.40

*Specifications subject to change without notice.