

EMI Suppression Capacitors X1 Class 440VAC

ME1X 440V Series

MERITEK

FEATURE

- Self-Healing Property
- Dielectric: Metallized Polypropylene Film
- Winding: Non-Inductive Type
- Over Voltage Stress Withstanding
- Flammability Classification 94V-0
- UL/cUL Safety Approved: Certification No: E197475



PART NUMBERING SYSTEM

ME1X 223 K 440V xxx
(1) (2) (3) (4) (5)



No	Item	Digit	Description	Reference
(1)	Meritek Series	ME1X	EMI Suppression Capacitors	X1 Class Safety Film Capacitor
(2)	Capacitance	223	223: 22000pF	First two digits: Significant, Third: Multiplier
(3)	Tolerance	K	K: $\pm 10\%$	$\pm 5\%$ (J), $\pm 20\%$ (M)
(4)	Rated Voltage	440V	440V: 440VAC	at 50~60Hz
(5)	Internal Code	xxx	Pitch or Internal control code	Internal Control or project reference

SPECIFICATIONS

Item	Characteristic	
Operating Temperature Range	-40°C ~ +110°C	
Rated Voltage , Climate Category	440VAC at 50~60Hz,	40/110/56/B
Capacitance, Tolerance	0.001 μ F ~ 10.0 μ F,	$\pm 5\%$ (J), $\pm 10\%$ (K), $\pm 20\%$ (M)
Dissipation Factor (tan δ)	$\leq 0.1\%$	at 1KHz $\pm 2\%$, $\leq 1.0V_{RMS}$
Insulation resistance at 100V _{DC} , Change Time: 60s $\pm 5s$	$\geq 15,000M\Omega$ (C $\leq 0.33\mu$ F)	$\geq 5,000M\Omega \cdot \mu$ F/C (C $> 0.33\mu$ F)
Withstanding Voltage	Between Terminals	Between Terminals and Case
	4.3*U _{DC} for 60s	2*U _r +1.5KV _{AC} for 2~5s, Min 2KV _{AC}

DIMENSION

P (mm)	d (mm)	W, H, T (mm)
7.5	0.6	See Table Attached
10.0	0.6	
15.0	0.6	
22.5	0.8	
27.5	0.8	
32.5	0.8	
37.5	1.0	
47.5	1.0	
52.5	1.0	

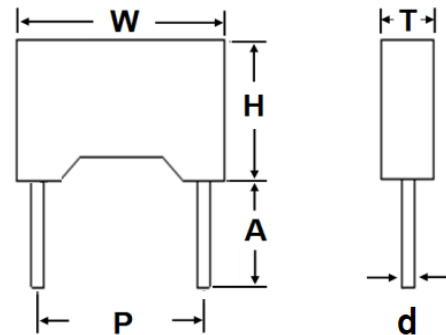

Note:

1. Standard lead length A: 15mm min.
2. Contact Meritek for other available options for lead forming or assembly

EMI Suppression Capacitors X1 Class 440VAC

ME1X 440V Series

MERITEK

ELECTRICAL SPECIFICATION – 440VAC

Part Number	Cap Code	Cap	Tol	Volt	W	H	T	P	d	Safety
		(uF)	(%)	(V _{AC})	(mm)	(mm)	(mm)	(mm)	(mm)	Compliance
ME1X102□440V75	102	0.0010	J,K,M	440	10.5	9.0	4.0	7.5	0.6	UL, cUL, ENEC
ME1X102□440V10	102	0.0010	J,K,M	440	13.0	11.0	5.0	10.0	0.6	UL, cUL, ENEC
ME1X102□440V15	102	0.0010	J,K,M	440	18.0	11.0	5.0	15.0	0.6	UL, cUL, ENEC
ME1X152□440V75	152	0.0015	J,K,M	440	10.5	9.0	4.0	7.5	0.6	UL, cUL, ENEC
ME1X152□440V10	152	0.0015	J,K,M	440	13.0	11.0	5.0	10.0	0.6	UL, cUL, ENEC
ME1X152□440V15	152	0.0015	J,K,M	440	18.0	11.0	5.0	15.0	0.6	UL, cUL, ENEC
ME1X222□440V75	222	0.0022	J,K,M	440	10.5	9.0	4.0	7.5	0.6	UL, cUL, ENEC
ME1X222□440V10	222	0.0022	J,K,M	440	13.0	11.0	5.0	10.0	0.6	UL, cUL, ENEC
ME1X222□440V15	222	0.0022	J,K,M	440	18.0	11.0	5.0	15.0	0.6	UL, cUL, ENEC
ME1X272□440V75	272	0.0027	J,K,M	440	10.5	9.0	4.0	7.5	0.6	UL, cUL, ENEC
ME1X272□440V10	272	0.0027	J,K,M	440	13.0	11.0	5.0	10.0	0.6	UL, cUL, ENEC
ME1X272□440V15	272	0.0027	J,K,M	440	18.0	11.0	5.0	15.0	0.6	UL, cUL, ENEC
ME1X332□440V75	332	0.0033	J,K,M	440	10.5	9.0	4.0	7.5	0.6	UL, cUL, ENEC
ME1X332□440V10	332	0.0033	J,K,M	440	13.0	11.0	5.0	10.0	0.6	UL, cUL, ENEC
ME1X332□440V15	332	0.0033	J,K,M	440	18.0	11.0	5.0	15.0	0.6	UL, cUL, ENEC
ME1X392□440V75	392	0.0039	J,K,M	440	10.5	9.0	4.0	7.5	0.6	UL, cUL, ENEC
ME1X392□440V10	392	0.0039	J,K,M	440	13.0	11.0	5.0	10.0	0.6	UL, cUL, ENEC
ME1X392□440V15	392	0.0039	J,K,M	440	18.0	11.0	5.0	15.0	0.6	UL, cUL, ENEC
ME1X472□440V75	472	0.0047	J,K,M	440	10.5	9.0	4.0	7.5	0.6	UL, cUL, ENEC
ME1X472□440V10	472	0.0047	J,K,M	440	13.0	11.0	5.0	10.0	0.6	UL, cUL, ENEC
ME1X472□440V15	472	0.0047	J,K,M	440	18.0	11.0	5.0	15.0	0.6	UL, cUL, ENEC
ME1X562□440V75	562	0.0056	J,K,M	440	10.5	9.0	4.0	7.5	0.6	UL, cUL, ENEC
ME1X562□440V10	562	0.0056	J,K,M	440	13.0	11.0	5.0	10.0	0.6	UL, cUL, ENEC
ME1X562□440V15	562	0.0056	J,K,M	440	18.0	11.0	5.0	15.0	0.6	UL, cUL, ENEC
ME1X682□440V75	682	0.0068	J,K,M	440	10.5	11.0	5.0	7.5	0.6	UL, cUL, ENEC
ME1X682□440V10	682	0.0068	J,K,M	440	13.0	11.0	5.0	10.0	0.6	UL, cUL, ENEC
ME1X682□440V15	682	0.0068	J,K,M	440	18.0	11.0	5.0	15.0	0.6	UL, cUL, ENEC
ME1X8222□440V75	8222	0.0082	J,K,M	440	10.5	11.0	5.0	7.5	0.6	UL, cUL, ENEC
ME1X8222□440V10	8222	0.0082	J,K,M	440	13.0	11.0	5.0	10.0	0.6	UL, cUL, ENEC
ME1X8222□440V15	8222	0.0082	J,K,M	440	18.0	11.0	5.0	15.0	0.6	UL, cUL, ENEC
ME1X103□440V75	103	0.010	J,K,M	440	10.5	11.0	5.0	7.5	0.6	UL, cUL, ENEC
ME1X103□440V10	103	0.010	J,K,M	440	13.0	11.0	5.0	10.0	0.6	UL, cUL, ENEC
ME1X103□440V15	103	0.010	J,K,M	440	18.0	11.0	5.0	15.0	0.6	UL, cUL, ENEC
ME1X123□440V75	123	0.012	J,K,M	440	10.5	12.0	6.0	7.5	0.6	UL, cUL, ENEC
ME1X123□440V10	123	0.012	J,K,M	440	13.0	11.0	5.0	10.0	0.6	UL, cUL, ENEC

Note: 1. □: denotes tolerance code; 2. Contact Meritek for Part Number on options on lead: diameter, length, and/or forming.

EMI Suppression Capacitors X1 Class 440VAC

ME1X 440V Series

MERITEK

ELECTRICAL SPECIFICATION – 440VAC

Part Number	Cap Code	Cap	Tol	Volt	W	H	T	P	d	Safety
		(uF)	(%)	(V _{AC})	(mm)	(mm)	(mm)	(mm)	(mm)	Compliance
ME1X123□440V15	123	0.012	J,K,M	440	18.0	11.0	5.0	15.0	0.6	UL, cUL, ENEC
ME1X153□440V75	153	0.015	M	440	10.5	12.0	6.0	7.5	0.6	UL, cUL, ENEC
ME1X153□440V10	153	0.015	J,K,M	440	13.0	11.0	5.0	10.0	0.6	UL, cUL, ENEC
ME1X153□440V15	153	0.015	J,K,M	440	18.0	11.0	5.0	15.0	0.6	UL, cUL, ENEC
ME1X183□440V10	183	0.018	J,K,M	440	13.0	11.0	5.0	10.0	0.6	UL, cUL, ENEC
ME1X183□440V15	183	0.018	J,K,M	440	18.0	11.0	5.0	15.0	0.6	UL, cUL, ENEC
ME1X223□440V10	223	0.022	J,K,M	440	13.0	11.0	5.0	10.0	0.6	UL, cUL, ENEC
ME1X223□440V15	223	0.022	J,K,M	440	18.0	11.0	5.0	15.0	0.6	UL, cUL, ENEC
ME1X273□440V10	273	0.027	J,K,M	440	13.0	12.0	6.0	10.0	0.6	UL, cUL, ENEC
ME1X273□440V15	273	0.027	J,K,M	440	18.0	11.0	5.0	15.0	0.6	UL, cUL, ENEC
ME1X333□440V10	333	0.033	J,K,M	440	13.0	12.0	6.0	10.0	0.6	UL, cUL, ENEC
ME1X333□440V15	333	0.033	J,K,M	440	18.0	11.0	5.0	15.0	0.6	UL, cUL, ENEC
ME1X393□440V10	393	0.039	J,K,M	440	13.0	13.0	7.0	10.0	0.6	UL, cUL, ENEC
ME1X393□440V15	393	0.039	J,K,M	440	18.0	12.0	6.0	15.0	0.6	UL, cUL, ENEC
ME1X393□440V22	393	0.039	J,K,M	440	25.0	14.5	6.0	22.5	0.8	UL, cUL, ENEC
ME1X473□440V10	473	0.047	M	440	13.0	13.0	7.0	10.0	0.6	UL, cUL, ENEC
ME1X473□440V15	473	0.047	J,K,M	440	18.0	12.0	6.0	15.0	0.6	UL, cUL, ENEC
ME1X473□440V22	473	0.047	J,K,M	440	25.0	14.5	6.0	22.5	0.8	UL, cUL, ENEC
ME1X563□440V10	563	0.056	J,K,M	440	13.0	14.0	8.0	10.0	0.6	UL, cUL, ENEC
ME1X563□440V15A	563	0.056	M	440	18.0	12.0	6.0	15.0	0.6	UL, cUL, ENEC
ME1X563□440V15B	563	0.056	J,K,M	440	18.0	13.5	6.0	15.0	0.6	UL, cUL, ENEC
ME1X563□440V22	563	0.056	J,K,M	440	25.0	14.5	6.0	22.5	0.8	UL, cUL, ENEC
ME1X683□440V15	683	0.068	J,K,M	440	17.0	15.5	7.5	15.0	0.6	UL, cUL, ENEC
ME1X683□440V22	683	0.068	J,K,M	440	25.0	14.5	6.0	22.5	0.8	UL, cUL, ENEC
ME1X823□440V15	823	0.082	J,K,M	440	17.0	15.5	7.5	15.0	0.6	UL, cUL, ENEC
ME1X823□440V22	823	0.082	J,K,M	440	25.0	14.5	6.0	22.5	0.8	UL, cUL, ENEC
ME1X104□440V15A	104	0.10	M	440	17.0	15.5	7.5	15.0	0.6	UL, cUL, ENEC
ME1X104□440V15B	104	0.10	J,K,M	440	18.0	14.5	8.5	15.0	0.6	UL, cUL, ENEC
ME1X104□440V22	104	0.10	J,K,M	440	25.0	14.5	6.0	22.5	0.8	UL, cUL, ENEC
ME1X124□440V15	124	0.12	J,K,M	440	17.0	16.5	9.5	15.0	0.6	UL, cUL, ENEC
ME1X124□440V22	124	0.12	J,K,M	440	25.0	14.5	6.0	22.5	0.8	UL, cUL, ENEC
ME1X154□440V15A	154	0.15	M	440	17.0	16.5	9.5	15.0	0.6	UL, cUL, ENEC
ME1X154□440V15B	154	0.15	J,K,M	440	17.0	19.0	11.0	15.0	0.6	UL, cUL, ENEC
ME1X154□440V22	154	0.15	J,K,M	440	26.5	16.5	7.0	22.5	0.8	UL, cUL, ENEC
ME1X154□440V27	154	0.15	J,K,M	440	31.5	16.5	7.5	27.5	0.8	UL, cUL, ENEC

Note: 1. □: denotes tolerance code; 2. Contact Meritek for Part Number on options on lead: diameter, length, and/or forming.

EMI Suppression Capacitors X1 Class 440VAC

ME1X 440V Series

MERITEK

ELECTRICAL SPECIFICATION – 440VAC

Part Number	Cap Code	Cap	Tol	Volt	W	H	T	P	d	Safety
		(uF)	(%)	(V _{AC})	(mm)	(mm)	(mm)	(mm)	(mm)	Compliance
ME1X184□440V15	184	0.18	J,K,M	440	17.0	19.0	11.0	15.0	0.6	UL, cUL, ENEC
ME1X184□440V22	184	0.18	J,K,M	440	26.5	17.5	8.5	22.5	0.8	UL, cUL, ENEC
ME1X224□440V22	224	0.22	J,K,M	440	26.5	17.5	8.5	22.5	0.8	UL, cUL, ENEC
ME1X224□440V27A	224	0.18	J,K,M	440	31.5	16.5	7.5	27.5	0.8	UL, cUL, ENEC
ME1X224□440V27B	224	0.22	J,K,M	440	32.0	18.0	9.0	27.5	0.8	UL, cUL, ENEC
ME1X274□440V22	274	0.27	J,K,M	440	26.5	19.0	10.0	22.5	0.8	UL, cUL, ENEC
ME1X274□440V27	274	0.27	J,K,M	440	32.0	18.0	9.0	27.5	0.8	UL, cUL, ENEC
ME1X304□440V37	304	0.30	J,K,M	440	41.0	22.0	11.0	37.5	1.0	UL, cUL, ENEC
ME1X334□440V37	334	0.33	J,K,M	440	41.0	22.0	11.0	37.5	1.0	UL, cUL, ENEC
ME1X334□440V22	334	0.33	J,K,M	440	26.0	20.0	11.0	22.5	0.8	UL, cUL, ENEC
ME1X334□440V27A	334	0.33	J,K,M	440	31.5	20.0	11.0	27.5	0.8	UL, cUL, ENEC
ME1X334□440V27B	334	0.33	J,K,M	440	32.0	12.0	18.0	27.5	0.8	UL, cUL, ENEC
ME1X334□440V32	334	0.33	J,K,M	440	37.0	24.0	13.5	32.5	0.8	UL, cUL, ENEC
ME1X394□440V22	394	0.39	J,K,M	440	26.0	20.0	11.0	22.5	0.8	UL, cUL, ENEC
ME1X394□440V27	394	0.39	J,K,M	440	31.5	20.0	11.0	27.5	0.8	UL, cUL, ENEC
ME1X394□440V32	394	0.39	J,K,M	440	37.0	24.0	13.5	32.5	0.8	UL, cUL, ENEC
ME1X394□440V37	394	0.39	J,K,M	440	41.0	22.0	11.0	37.5	1.0	UL, cUL, ENEC
ME1X404□440V37	404	0.40	J,K,M	440	41.0	22.0	11.0	37.5	1.0	UL, cUL, ENEC
ME1X474□440V22A	474	0.47	M	440	26.0	21.5	12.0	22.5	0.8	UL, cUL, ENEC
ME1X474□440V22B	474	0.47	J,K,M	440	25.0	23.5	14.0	22.5	0.8	UL, cUL, ENEC
ME1X474□440V27A	474	0.47	M	440	31.5	20.0	11.0	27.5	0.8	UL, cUL, ENEC
ME1X474□440V27B	474	0.47	J,K,M	440	32.0	22.0	12.0	27.5	0.8	UL, cUL, ENEC
ME1X474□440V32	474	0.47	J,K,M	440	37.0	24.0	13.5	32.5	0.8	UL, cUL, ENEC
ME1X474□440V37	474	0.47	J,K,M	440	41.0	22.0	11.0	37.5	1.0	UL, cUL, ENEC
ME1X504□440V37	504	0.50	J,K,M	440	41.0	22.0	11.0	37.5	1.0	UL, cUL, ENEC
ME1X524□440V22	524	0.52	J,K,M	440	25.0	23.5	14.0	22.5	0.8	UL, cUL, ENEC
ME1X564□440V22A	564	0.56	M	440	25.0	23.5	14.0	22.5	0.8	UL, cUL, ENEC
ME1X564□440V22B	564	0.56	J,K,M	440	26.0	25.0	15.0	22.5	0.8	UL, cUL, ENEC
ME1X564□440V27	564	0.56	J,K,M	440	31.5	22.5	13.0	27.5	0.8	UL, cUL, ENEC
ME1X564□440V32	564	0.56	J,K,M	440	37.0	24.0	13.5	32.5	0.8	UL, cUL, ENEC
ME1X564□440V37	564	0.56	J,K,M	440	41.0	22.0	11.0	37.5	1.0	UL, cUL, ENEC
ME1X604□440V27	604	0.60	J,K,M	440	31.5	25.0	14.0	27.5	0.8	UL, cUL, ENEC
ME1X684□440V22	684	0.68	M	440	26.0	25.0	15.0	22.5	0.8	UL, cUL, ENEC
ME1X684□440V27A	684	0.68	M	440	31.5	22.5	13.0	27.5	-	UL, cUL, ENEC
ME1X684□440V27B	684	0.68	J,K,M	440	31.5	25.0	14.0	27.5	0.8	UL, cUL, ENEC

Note: 1. □: denotes tolerance code; 2. Contact Meritek for Part Number on options on lead: diameter, length, and/or forming.

EMI Suppression Capacitors X1 Class 440VAC

ME1X 440V Series

MERITEK

ELECTRICAL SPECIFICATION – 440VAC

Part Number	Cap Code	Cap	Tol	Volt	W	H	T	P	d	Safety
		(uF)	(%)	(V _{AC})	(mm)	(mm)	(mm)	(mm)	(mm)	Compliance
ME1X684□440V27C	684	0.68	J,K,M	440	32.0	16.0	22.0	27.5	0.8	UL, cUL, ENEC
ME1X684□440V32	684	0.68	J,K,M	440	37.0	24.0	13.5	32.5	0.8	UL, cUL, ENEC
ME1X684□440V37	684	0.68	J,K,M	440	41.0	22.0	11.0	37.5	1.0	UL, cUL, ENEC
ME1X804□440V32	804	0.80	J,K,M	440	37.0	26.5	16.0	32.5	0.8	UL, cUL, ENEC
ME1X824□440V27A	824	0.82	M	440	31.5	25.0	14.0	27.5	0.8	UL, cUL, ENEC
ME1X824□440V27B	824	0.82	J,K,M	440	32.0	28.0	14.0	27.5	0.8	UL, cUL, ENEC
ME1X824□440V32	824	0.82	M	440	37.0	24.0	13.5	32.5	0.8	UL, cUL, ENEC
ME1X824□440V37A	824	0.82	M	440	41.0	22.0	11.0	37.5	1.0	UL, cUL, ENEC
ME1X824□440V37B	824	0.82	J,K,M	440	41.0	26.0	12.0	37.5	1.0	UL, cUL, ENEC
ME1X105□440V27A	105	1.0	M	440	32.0	16.0	27.5	27.5	0.8	UL, cUL, ENEC
ME1X105□440V27B	105	1.0	J,K,M	440	32.0	18.5	31.0	27.5	0.8	UL, cUL, ENEC
ME1X105□440V27C	105	1.0	J,K,M	440	32.0	28.0	18.0	27.5	0.8	UL, cUL, ENEC
ME1X105□440V32A	105	1.0	M	440	37.0	26.5	16.0	32.5	0.8	UL, cUL, ENEC
ME1X105□440V32B	105	1.0	J,K,M	440	37.0	28.5	18.0	32.5	0.8	UL, cUL, ENEC
ME1X105□440V37A	105	1.0	J,K,M	440	41.0	26.0	12.0	37.5	1.0	UL, cUL, ENEC
ME1X105□440V37B	105	1.0	J,K,M	440	42.0	15.0	24.0	37.5	1.0	UL, cUL, ENEC
ME1X125□440V27A	125	1.2	M	440	32.0	28.0	18.0	27.5	0.8	UL, cUL, ENEC
ME1X125□440V27B	125	1.2	J,K,M	440	32.0	29.0	19.0	27.5	0.8	UL, cUL, ENEC
ME1X125□440V32A	125	1.2	M	440	37.0	28.5	18.0	32.5	0.8	UL, cUL, ENEC
ME1X125□440V32B	125	1.2	J,K,M	440	35.5	31.0	20.0	32.5	0.8	UL, cUL, ENEC
ME1X125□440V37A	125	1.2	J,K,M	440	41.0	26.0	15.0	37.5	1.0	UL, cUL, ENEC
ME1X125□440V37B	125	1.2	J,K,M	440	41.0	28.0	14.0	37.5	1.0	UL, cUL, ENEC
ME1X155□440V27A	155	1.5	M	440	32.0	29.0	19.0	27.5	0.8	UL, cUL, ENEC
ME1X155□440V27B	155	1.5	M	440	32.0	18.5	31.0	27.5	0.8	UL, cUL, ENEC
ME1X155□440V27C	155	1.5	J,K,M	440	31.0	31.0	22.0	27.5	0.8	UL, cUL, ENEC
ME1X155□440V32A	155	1.5	M	440	35.5	31.0	20.0	32.5	0.8	UL, cUL, ENEC
ME1X155□440V32B	155	1.5	J,K,M	440	37.0	34.0	22.0	32.5	0.8	UL, cUL, ENEC
ME1X155□440V37A	155	1.5	M	440	41.0	28.0	14.0	37.5	1.0	UL, cUL, ENEC
ME1X155□440V37B	155	1.5	M	440	41.0	26.0	15.0	37.5	1.0	UL, cUL, ENEC
ME1X155□440V37C	155	1.5	J,K,M	440	41.0	30.0	16.0	37.5	1.0	UL, cUL, ENEC
ME1X155□440V37D	155	1.5	J,K,M	440	42.0	19.0	24.0	37.5	1.0	UL, cUL, ENEC
ME1X185□440V27	185	1.8	J,K,M	440	32.0	37.0	22.0	27.5	0.8	UL, cUL, ENEC
ME1X185□440V32	185	1.8	J,K,M	440	37.0	34.0	22.0	32.5	0.8	UL, cUL, ENEC
ME1X185□440V37A	185	1.8	M	440	41.0	30.0	16.0	37.5	1.0	UL, cUL, ENEC
ME1X185□440V37B	185	1.8	J,K,M	440	41.0	32.0	17.0	37.5	1.0	UL, cUL, ENEC

Note: 1. □: denotes tolerance code; 2. Contact Meritek for Part Number on options on lead: diameter, length, and/or forming.

EMI Suppression Capacitors X1 Class 440VAC

ME1X 440V Series

MERITEK

ELECTRICAL SPECIFICATION – 440VAC

Part Number	Cap Code	Cap	Tol	Volt	W	H	T	P	d	Safety
		(uF)	(%)	(V _{AC})	(mm)	(mm)	(mm)	(mm)	(mm)	Compliance
ME1X225□440V27	225	2.2	M	440	32.0	37.0	22.0	27.5	0.8	UL, cUL, ENEC
ME1X225□440V32	225	2.2	M	440	37.0	34.0	22.0	32.5	0.8	UL, cUL, ENEC
ME1X225□440V37A	225	2.2	M	440	41.0	32.0	17.0	37.5	1.0	UL, cUL, ENEC
ME1X225□440V37B	225	2.2	J,K,M	440	41.0	33.5	19.5	37.5	1.0	UL, cUL, ENEC
ME1X275□440V37	275	2.7	J,K,M	440	41.0	37.0	22.0	37.5	1.0	UL, cUL, ENEC
ME1X335□440V37A	335	3.3	M	440	41.0	37.0	22.0	37.5	1.0	UL, cUL, ENEC
ME1X335□440V37B	335	3.3	J,K,M	440	41.5	41.0	27.5	37.5	1.0	UL, cUL, ENEC
ME1X395□440V37	395	3.9	J,K,M	440	41.0	43.0	28.0	37.5	1.0	UL, cUL, ENEC
ME1X445□440V37	445	4.4	J,K,M	440	41.0	43.0	28.0	37.5	1.0	UL, cUL, ENEC
ME1X445□440V47	445	4.4	J,K,M	440	51.0	43.5	29.0	47.5	1.0	UL, cUL, ENEC
ME1X445□440V52	445	4.4	J,K,M	440	57.0	38.0	24.0	52.5	1.0	UL, cUL, ENEC
ME1X475□440V37A	475	4.7	M	440	41.0	43.0	28.0	37.5	1.0	UL, cUL, ENEC
ME1X475□440V37B	475	4.7	J,K,M	440	42.0	45.0	30.0	37.5	1.0	UL, cUL, ENEC
ME1X475□440V47	475	4.7	J,K,M	440	51.0	43.5	29.0	47.5	1.0	UL, cUL, ENEC
ME1X475□440V52	475	4.7	J,K,M	440	57.0	38.0	24.0	52.5	1.0	UL, cUL, ENEC
ME1X565□440V47	565	5.6	M	440	51.0	43.5	29.0	47.5	1.0	UL, cUL, ENEC
ME1X565□440V52A	565	5.6	M	440	57.0	38.0	24.0	52.5	1.0	UL, cUL, ENEC
ME1X565□440V52B	565	5.6	J,K,M	440	57.0	45.0	30.0	52.5	1.0	UL, cUL, ENEC
ME1X685□440V47	685	6.8	J,K,M	440	51.0	49.5	35.0	47.5	1.0	UL, cUL, ENEC
ME1X685□440V52A	685	6.8	J,K,M	440	57.0	50.0	35.0	52.5	1.0	UL, cUL, ENEC
ME1X685□440V52B	685	6.8	M	440	57.0	45.0	30.0	52.5	1.0	UL, cUL, ENEC
ME1X685□440V52C	685	6.8	M	440	57.0	30.0	44.0	52.5	1.0	UL, cUL, ENEC
ME1X825□440V47	825	8.2	M	440	51.0	49.5	35.0	47.5	1.0	UL, cUL, ENEC
ME1X825□440V52	825	8.2	J,K,M	440	57.0	50.0	35.0	52.5	1.0	UL, cUL, ENEC
ME1X106□440V52A	106	10.0	M	440	57.0	50.0	35.0	52.5	1.0	UL, cUL, ENEC
ME1X106□440V52B	106	10.0	J,K,M	440	57.0	55.0	45.0	52.5	1.0	UL, cUL, ENEC

Note: 1. □: denotes tolerance code; 2. Contact Meritek for Part Number on options on lead: diameter, length, and/or forming.

RELIABILITY AND TEST CONDITIONS

Item	Test Condition	Requirement
Capacitance	Measuring Frequency: ±2%, Measuring Voltage: ≤1Vrms.	Within the tolerance specified, at +20±5°C
Withstand Voltage - Between Terminals	Apply 4.3 times of rated voltage for 60s	Within specified limits
Withstand Voltage - Between Terminals & Enclosure	Apply 2 times of rated voltage 1.5KV _{AC} for 2~5s; Min. 2KV _{AC}	Within specified limits
Dissipation Factor	Measuring Frequency: ±2%, Measuring Voltage: ≤1Vrms.	D.F. : ≤0.001(0.1%) at 1KHz

EMI Suppression Capacitors X1 Class 440VAC

ME1X 440V Series

MERITEK

RELIABILTY AND TEST CONDITIONS

Item	Test Condition	Requirement																	
Insulation resistance	Measured at 100V, 60±5 Sec	Cr≤0.33uF IR≥15,000MΩ Cr>0.33uF IR≥5,000MΩ*uF/C																	
Solderability	Soldering temperature: +235±5°C Immersion duration: 2±0.5sec	More than 90% of circumferential surface of lead wire shall be covered with new solder																	
Tensile Terminal Strength	Apply 1.0Kg (10N) for 10±1sec to the terminal in the axial direction and acting in a direction away from the body.	Shall be no abnormality																	
Damp Heat	Temperature: +40°C ± 2°C, Relative Humidity: 90%~95% Time: 56days; After test, let rest for 1.5±0.5hr at ordinary condition before making measurements.	Appearance : No Visible Damage Withstand Voltage: Within specified limits ΔC/C: ≤ ±5% of the value before test DF: ≤ 0.002 (0.2%) Max at 1KHz IR: ≥ 50% of the rated value																	
Dry Heat Resistance	Temperature: 110°C ± 2°C, Times: 16 +1/-0Hrs																		
Cold Resistance	Temperature: -40±3°C, Times: 2±1Hrs																		
Temperature Cycle	Test Temperature Cycle: Total 5 cycles. Each cycle includes <table border="1"> <thead> <tr> <th>Cycle</th> <th>Temperature</th> <th>Time</th> </tr> </thead> <tbody> <tr> <td>1</td> <td>+20±2°C</td> <td>3 min</td> </tr> <tr> <td>2</td> <td>-40±3°C</td> <td>30min</td> </tr> <tr> <td>3</td> <td>+20±2°C</td> <td>3 min</td> </tr> <tr> <td>4</td> <td>+110±2°C</td> <td>30min</td> </tr> <tr> <td>5</td> <td>+20±2°C</td> <td>3 min</td> </tr> </tbody> </table> After test, let rest for 1.5±0.5hr at ordinary condition before making measurements.		Cycle	Temperature	Time	1	+20±2°C	3 min	2	-40±3°C	30min	3	+20±2°C	3 min	4	+110±2°C	30min	5	+20±2°C
Cycle	Temperature	Time																	
1	+20±2°C	3 min																	
2	-40±3°C	30min																	
3	+20±2°C	3 min																	
4	+110±2°C	30min																	
5	+20±2°C	3 min																	
Vibration Resistance	Frequency change: 10~55~10Hz Vibration Distance: 1.5mm Test Direction: X, Y, Z Test Duration: 2+1/-0hrs each direction	Appearance : No mechanical Damage Connection: Shall be no short or open																	
Soldering Heat Resistance	Preheat Temperature: 100~120°C Preheat Duration: 60sec max Temperature increase by 3°C/sec max Soldering Temperature: +260±5°C Immersion Duration: 5±1sec Immersion Depth: 4±0.8mm from roots After test, allow it stay alone for 1.5±0.5hrs at ordinary condition before making measurements	Appearance: No Visible Damage Withstand Voltage: Within specified limits ΔC/C: ≤ ±3% of the value before test DF: ≤ 0.002 (0.2%) Max at 1KHz IR: ≥ 50% of the rated value																	
Endurance	Duration: 1,000 hours, Temperature: +110± 2°C Voltage: 1.25 times rated voltage. Once every hour the voltage increased to 1KVrms. For 0.1sec. The test voltage is applied to each capacitor individually through a Resistor of 47Ω±5%.	Appearance : No Visible Damage ΔC/C: ≤ ±10% of the value before test DF: ≤ 0.008 Max at 1KHz; for Cr≤1μF DF: ≤ 0.005 Max at 1KHz; for Cr>1μF IR: ≥ 50% of the rated value																	
Humidity Resistance	Test Temperature: -40±2°C Test Humidity: 87% to 93% R.H. Test Voltage: rated voltage Test Duration: 500 hours After test, allow it stay alone for 1.5±0.5hrs at ordinary condition before making measurements	Appearance: No Visible Damage Withstand Voltage: Within specified limits ΔC/C: ≤ ±5% of the value before test DF: ≤ 0.002 (0.2%) Max at 1KHz IR: ≥ 50% of the rated value																	

Notes:

1. Ambient Temp: 15°C to 35°C, Relative Humidity (R.H.): 45% to 75%, Air Pressure: 86kpa to 106kpa
2. Operating Temperature: -40~110°C
3. Storage needs to be kept indoors at -10~+40°C and relative humidity of under 75% without any sudden temperature changes, direct sunlight and corrosive gas around
4. Do not apply and exceeding vibration, shock (dropping) and pressure

*Specifications subject to change without notice.